

<b>PRECAUTIONS</b>	<b>3</b>	Preliminary operations	10
General safety instructions	3	Using the accessories	10
Installation	6	Using the hob	10
Appliance purpose	8	<b>CLEANING AND MAINTENANCE</b>	<b>12</b>
This user manual	8	Cleaning the hob	12
Manufacturer's liability	8	Cleaning the hob	12
Identification plate	8	What to do if...	13
Disposal	8	<b>INSTALLATION</b>	<b>13</b>
To save energy	8	Gas connection	13
How to read the user manual	9	Burner and nozzle characteristics tables	16
<b>DESCRIPTION</b>	<b>9</b>	Electrical connection	16
General description	9	Section cut from the countertop	17
<b>USE</b>	<b>10</b>	Mounting	18
Precautions	10	Fixing to the built-in cabinet	19
		Instructions for the installer	19

We advise you to read this manual carefully, which contains all the instructions for maintaining the appliance's aesthetic and functional qualities. For further information on the product: [www.smeg.com](http://www.smeg.com)

These instructions apply only to the destination countries listed on the appliance's data plate.

This is a class 3 built-in hob.

## PRECAUTIONS

### General safety instructions

#### Risk of personal injury

- During use the appliance and its accessible parts become very hot. Keep children well away from the appliance.
- Protect hands with heat resistant gloves during use.
- Never try to put out a fire or flames with water: Turn off the appliance and smother the flames with a fire blanket or other appropriate cover.
- This appliance may only be used by children aged 8 years and over, and by people of reduced physical, sensory or mental capacity, or lacking in experience in the use of electrical appliances, provided that they are supervised or have been given instructions on the safe use of the appliance and of the hazards associated with it.
- Children must not play with the appliance.
- Keep children under the age of eight at a safe distance unless they are constantly supervised.
- Keep children under the age of 8 away from the appliance when it is in use.
- Cleaning and maintenance must not be carried out by unsupervised children.
- Make sure that the flame-

- spreader crowns are correctly positioned in their housings with their respective burner caps.
- Do not touch or clean the surface of the hob while it is in use.
  - The cooking process must always be kept under control. A short cooking process must be continuously monitored.
  - **WARNING:** Cooking foods containing fat and/or oil without monitoring them can be dangerous and can cause a fire.
  - Fats and oils can catch fire if they overheat. Do not leave the appliance unattended while preparing foods containing oils or fats. If fats or oils catch fire, never put water on them. Place the lid on the pan and turn off the relevant cooking zone.
  - Do not place metal objects, such as dishes or cutlery, on the surface of the hob during cooking as they may overheat.
  - **WARNING:** leaving food unattended when cooking using fat or oil can be dangerous and can cause a fire. **DO NOT** attempt to extinguish a fire with water. Turn off the appliance and smother the flames, for example with a lid or a blanket.
  - Do not cook foods in closed tins or containers or plastic containers.
  - Do not insert pointed metal objects (cutlery or utensils) into the slots in the appliance.
  - Do not use or store flammable materials near the appliance or directly underneath the hob.
  - Switch off the burners immediately after use.
  - Do not pull the cable to unplug the appliance (if present).
  - **DO NOT USE AEROSOLS IN THE VICINITY OF THIS APPLIANCE WHILST IT IS IN USE.**
  - **DO NOT MODIFY THIS APPLIANCE.**
  - Always wear personal protective equipment (PPE) before carrying out any work on the appliance (installation, maintenance, positioning or moving).
  - Do not clean the appliance if it is still hot or in operation.
  - Before performing any work on the appliance, switch off the power supply.
  - Do not try to repair the appliance yourself or without the assistance of a qualified technician.
  - If the power cable becomes damaged, contact technical support immediately to arrange for it to be replaced in order to avoid possible hazards.
  - If cracks or fissures form, or if the glass cooking surface breaks, turn off the appliance

immediately. Disconnect the power supply and call Technical Support.

- **WARNING:** A gas cooking appliance produces heat, humidity and combustion products in the room where it is installed. Make sure there is good ventilation, especially when the appliance is in use: keep the natural ventilation openings open or install a mechanical ventilation device.
- Intensive and prolonged use of the appliance may require additional ventilation, for example opening a window or more effective ventilation; for example by increasing the power of any mechanical suction devices.
- **DO NOT FOR ANY REASON USE THE APPLIANCE AS A SPACE HEATER.**
- Lids or covers, including those of third parties, are not suitable for use on this appliance.

### **Risk of damaging the appliance**

- Do not use abrasive or corrosive detergents (e.g. scouring powders, stain removers and metallic sponges) on glass parts.
- Use wooden or plastic utensils.
- Do not sit on the appliance.
- Do not use the glass surface as a support surface.
- Do not use the appliance as a

support surface.

- Do not obstruct ventilation openings and heat dispersal slots.
- Do not use the hob if the pyrolytic cycle is taking place inside any oven installed below.
- Do not use steam jets to clean the appliance.
- Never leave the appliance unattended during cooking operations where fats or oils could be released, as these could then heat up and catch fire. Be very careful.
- Fire hazard: Never leave objects on the cooking surfaces.
- Pans or griddles should be placed inside the perimeter of the hob.
- All pans must have smooth, flat bottoms.
- If any liquid does boil over or spill, remove the excess from the hob.
- Do not use pans/griddles made of terracotta, earthenware or steatite.
- Take care not to spill acid substances such as lemon juice or vinegar on the hob.
- Do not spill sugar or sweet mixtures on the hob during cooking.
- Do not place materials or substances that could melt or catch fire (paper, plastic or

aluminium foil) on the appliance while it is in use.

- Do not place pans directly on the burners.
- Do not put empty pans or frying pans on burners that are lit.
- Do not use rough or abrasive materials or sharp metal scrapers.
- Do not use cleaning products containing chlorine, ammonia or bleach on parts made of steel or that have metallic surface finishes (e.g. anodizing, nickel- or chromium-plating).
- Do not wash removable parts such as the hob pan support grids, flame-spreader crowns and burner caps in the dishwasher.
- This appliance is not designed to operate with external timers or with remote-control systems.
- To avoid damaging the racks, do not drag the pans; lift and reposition them instead.
- This appliance can be used up to a maximum altitude of 2,000 metres above sea level.

## Instructions for using pans



Do not place anything, e.g. flame tamer, asbestos mat, between pan and pan supports as serious damage to the appliance may result.



Do not remove the pan support and enclose the burner with a wok stand as this will concentrate and deflect heat onto the hotplate.



Do not use large pots or heavy weights that can bend the pan support or deflect flame onto the hotplate.

## Installation

- THIS APPLIANCE **MUST NOT BE INSTALLED IN BOATS OR CARAVANS.**
- This appliance must not be installed on a dishwasher.
- Position the appliance into the cabinet cut-out with the help of a second person.
- Before installation, make sure that the local distribution conditions (type and pressure of the gas) and the regulation of the appliance are compatible.
- This appliance is not connected to a system for extracting combustion products. It should be installed and connected in compliance with current installation regulations. Pay particular attention to the requirements regarding ventilation.
- The settings for this appliance

are shown on the gas settings label.

- Have the gas connection performed by authorised personnel.
- Have the electrical connection performed by authorised technical personnel.
- Installation using a hose must be carried out so that the length of the hose does not exceed 2 metres when fully extended for steel hoses and 1.5 metres for rubber hoses.
- The gas connection hoses must not come into contact with moving parts of the built-in module (for example a drawer) and must not be routed through a space that could cause it to be pinched.
- If required, use a pressure regulator that complies with current regulations.
- After carrying out any operation, check that the tightening torque of gas connections is between 10 Nm and 15 Nm.
- At the end of the installation, check for any leaks with a soapy solution, never with a flame.
- Check that the carcass has the required openings.
- Check that the carcass material is heat resistant.
- Installation and servicing should be carried out by qualified personnel in accordance with current standards.
- The appliance must be connected to earth in compliance with electrical system safety standards.
- Use cables that can withstand temperatures of at least 90°C.
- Run the power cable in the rear part of the unit. Make sure that it does not come into contact with the lower part of the hob or a built-in oven below it.
- Be careful when connecting additional electrical appliances. Connection cables must not come into contact with hot cooking zones.
- The tightening torque of the screws of the terminal supply wires must be 1.5 - 2 Nm.
- The power cable must only be installed or replaced by a qualified technician.
- If the power cable becomes damaged, contact technical support immediately to arrange for it to be replaced in order to avoid possible hazards.
- Always use any necessary/required personal protective equipment (PPE) before performing any work on the appliance (installation, maintenance, positioning or movement).
- Before performing any work on the appliance, switch off the power supply.

- Allow the appliance to be disconnected after installation, via an accessible plug or a switch in the case of a fixed connection.
- Fit the power line with an all-pole circuit breaker with a contact separation distance sufficient to provide complete disconnection in category III overvoltage conditions, pursuant to installation regulations.
- You should make sure that the appliance is working correctly (rotation of knobs, positioning of the pan supports etc.) only once it has been installed and secured to the unit.

## Appliance purpose

This appliance is intended for cooking food in the home environment. Every other use is considered inappropriate. It cannot be used:

- in employee kitchens, shops, offices and other working environments.
- in farms/farmhouses.
- by guests in hotels, motels and residential environments.
- In bed and breakfast accommodation.

## This user manual

- This user manual is an integral part of the appliance and must therefore be kept in its entirety and within the user's reach for the whole working life of the appliance.
- Read this user manual carefully before using the appliance.

- The explanations in this manual include images, which describe all that regularly appears on the display. However, it should be kept in mind that the appliance may be equipped with an updated version of the system, and as such, all that appears on the display may differ from those in the manual.

## Manufacturer's liability

The manufacturer declines all liability for damage to persons or property caused by:

- use of the appliance other than that specified;
- failure to comply with the instructions in the user manual;
- tampering with any part of the appliance;
- use of non-original spare parts.

## Identification plate

The identification plate bears the technical data, serial number and brand name of the appliance. Do not remove the identification plate for any reason.

## Disposal



**Power voltage  
Danger of electrocution**

- Disconnect the mains power supply.
- Unplug the appliance.

To dispose of the appliance:

- Cut the power cable and remove it.
- Deliver the appliance to the appropriate recycling centre for electrical and electronic equipment waste, or return it to the retailer when purchasing an equivalent product, on a one for one basis.

Our appliances are packaged in non-polluting and recyclable materials.

- Take the packing materials to appropriate selective collection centres.



**Plastic packaging  
Danger of suffocation**

- Do not leave the packaging or any part of it unattended.
- Do not let children play with the plastic bags.

## To save energy

- When buying a pan, check whether the diameter indicated is that of the base or the



top of the pan, as the top is almost always larger than the base.

- When preparing dishes with long cooking times, you can save time and energy by using a pressure cooker, which also helps to retain vitamins contained in the food.
- Make sure that the pressure cooker contains enough liquid as, if there is not enough and it overheats, this may cause damage to both the pressure cooker and the cooking zone.
- If possible, always cover pans with a suitable lid.
- Choose a pan suitable for the quantity of

food to be cooked. A large, half-empty saucepan leads to a waste of energy.

### How to read the user manual

This user manual uses the following reading conventions:

	Warning/ Caution
	Information/ Advice

## DESCRIPTION

### General description

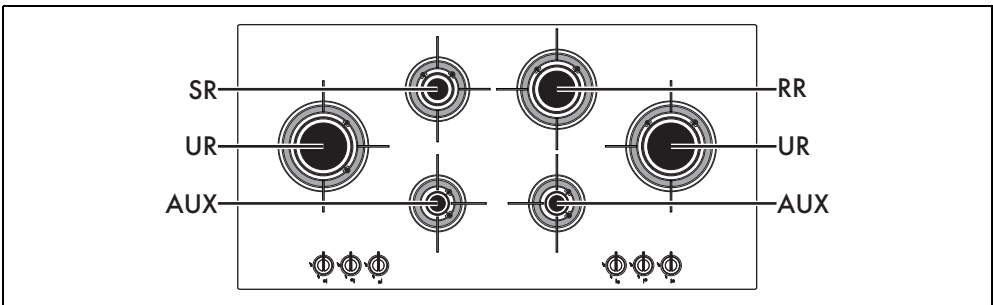
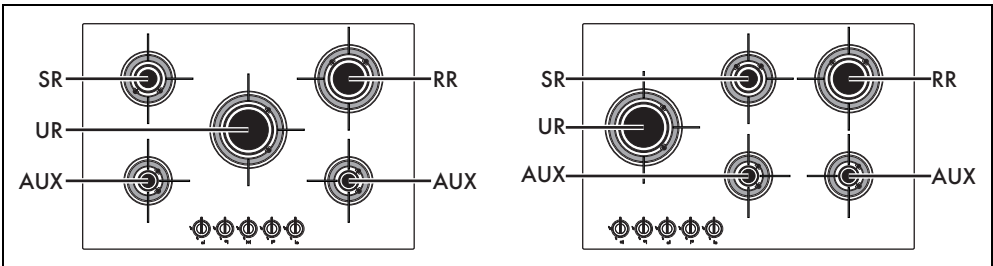
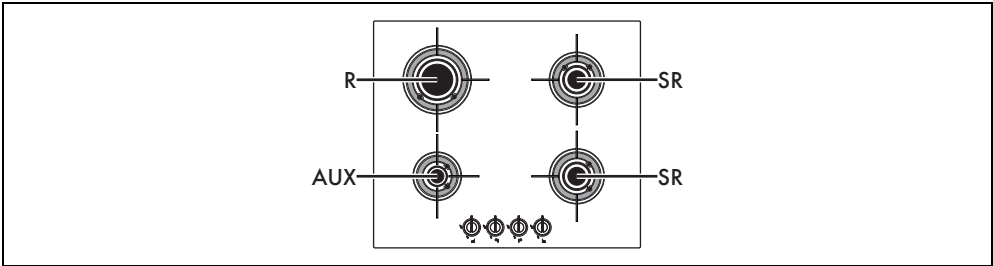

AUX: Auxiliary burner  
 SR: Semi-rapid burner  
 R: Rapid burner





RR: Reduced rapid burner  
 UR: Ultra-rapid burner

## Gas cooking zone

- Front left zone
- Left central zone
- Rear left zone
- Rear right zone
- Right central zone
- Front right zone

- Central zone

## Burner knobs

For lighting and adjusting the hob burners. Press and turn the knobs anti-clockwise to  in order to light the relative burners. Turn the knobs to the zone between the maximum  and minimum  setting to adjust the flame. Return the knobs to the position  to turn off the burners.

# USE

## Precautions



See General safety instructions.

### A gas leak can cause an explosion.

If you smell gas or there are faults in the gas system:

- Immediately turn off the gas supply or close the valve on the gas cylinder.
- Extinguish all naked flames and cigarettes.
- Do not turn on power switches or appliances and do not remove plugs from power sockets. Do not use phones or mobile phones inside the building.
- Open the window in order to ventilate the room.
- Call customer assistance services or your gas supplier.

## Malfunctions

Any of the following indicate a malfunction and you should contact a service centre.

- The burners do not ignite properly.
- It is difficult to keep the burners lit.
- The burners go out when the appliance is in use.
- It is difficult to turn the gas cocks.

## Preliminary operations



See General safety instructions.

- Remove any protective film from the outside or inside of the appliance, including any accessories (if present).
- Remove any labels (apart from the technical data plate).

## Practical tips for using the hob

For better burner efficiency, to minimise gas consumption and prevent damage to the cooking hob, use pans with lids and of suitable size for the burner, so that the flames do not reach up the sides of the pan. Once the contents come to the boil, turn down the flame far enough to ensure that the liquid does not boil over.

Burner	Pan diameter
AUX	12 - 18 cm
SR	14 - 24 cm
R	20 - 26 cm
RR	18 - 24 cm
UR	20 - 30 cm

## Using the accessories

### Using the hob

All the appliance's control and monitoring devices are located together on the front panel. The burner controlled by each knob is shown next to the knob. The appliance is equipped with an electronic ignition device. Simply press the knob and turn it anti-clockwise to the maximum flame symbol, until the burner ignites. If the burner does not light in the first 15 seconds, turn the knob to  and wait 60 seconds before trying again. After lighting, keep the knob pressed in for a few seconds to allow the thermocouple to heat up. The burner may go out when the knob is released: In this case, the thermocouple has not heated up sufficiently. Wait a few moments and repeat the operation.



Keep the knob pressed in longer.



In case of an accidental switching off, a safety device will be tripped, cutting off the gas supply, even if the gas cock is open. Return the knob to  and wait at least 60 seconds before lighting it again.

### Correct positioning of the flame-spreader crowns and burner caps

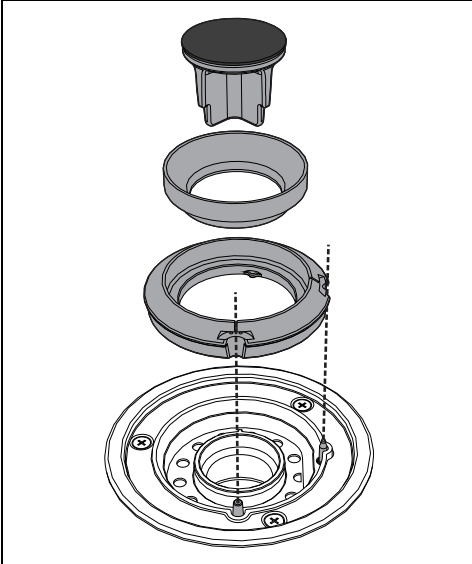

Before lighting the hob burners, make sure that the flame-spreader crowns are correctly positioned in their housings with their respective burner caps. Make sure that the holes in the burners are aligned with the thermocouples and the spark ignitions. Also ensure that the flame-spreader crowns are correctly engaged in the burner holes.

### Correct positioning of the pan supports

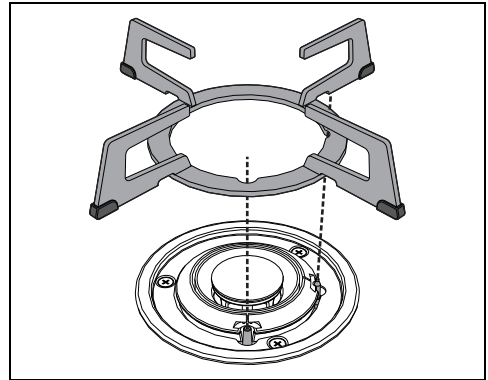

Make sure that the pan supports are simply centred on their respective burners, without forcing them to be raised or tilted. If they are, repeat the positioning procedure.

If you find that a pan is particularly unstable, make sure that the grids have not been positioned incorrectly.

### Precautions when using the griddle

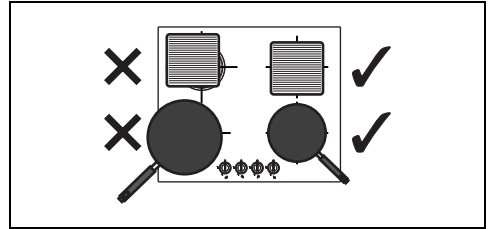

A few precautions are necessary if you wish to use a griddle:

- The griddle must not extend beyond the edge of the hob.
- Do not place the griddle over more than one burner at the same time.
- The griddle can be pre-heated on the burner at maximum power for no more than 10 minutes.
- Make sure that the burner flame does not extend beyond the edge of the griddle.
- Keep a distance of at least 150 mm between the griddle and the side and/or rear wall, especially if it is placed on an Ultra-Rapid burner.
- Never use the griddle for more than 40 minutes.

# CLEANING AND MAINTENANCE

## Cleaning the hob

### Cooking hob pan support grids

Remove the pan support grids and clean them in lukewarm water and non-abrasive detergent. Make sure to remove any encrustations. Dry them thoroughly and return them to the hob.



The continuous contact between the pan supports and the flame can cause modifications to the enamel over time in those parts exposed to heat. This is a completely natural phenomenon which has no effect on the operation of this component.

### Flame-spreader crown and burner caps

For easier cleaning, the flame-spreader crowns and the burner caps can be removed. Wash them in hot water and non-abrasive detergent. Carefully remove any encrustation, then wait until they are perfectly dry. Replace the flame-spreader crowns, making sure that they are correctly positioned in their housings with their respective burner caps.

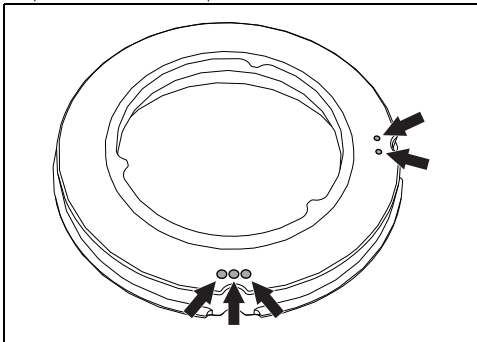

### Igniters and thermocouples

For correct operation the igniters and thermocouples must always be perfectly clean. Check them frequently and clean them with a damp cloth if necessary. Remove any dry

residues with a wooden toothpick or a needle.

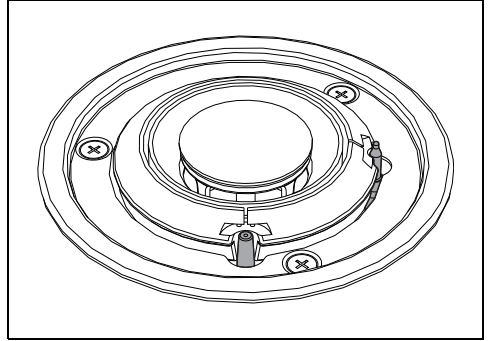

## Cleaning the hob



See General safety instructions.

### Cleaning the surfaces

To keep the surfaces in good condition, they should be cleaned regularly after use. Let them cool first.

### Ordinary daily cleaning

Always and only use specific products that do not contain abrasives or chlorine-based acids. Pour the product onto a damp cloth and wipe the surface, rinse thoroughly and dry with a soft cloth or a microfibre cloth.

### Weekly cleaning

Clean and maintain the hob once a week using an ordinary glass cleaning product. Always follow the manufacturer's instructions. The silicon in these products creates a protective, water-repellent membrane which also resists dirt. All marks stay on the membrane and can therefore be removed easily. After cleaning, dry the surface with a clean cloth. Make sure that there is no detergent left on the cooking surface as it might undergo an aggressive reaction when heated up and could modify the structure of the cooking surface.

### Food stains or residues

Light coloured marks from pans with aluminium bases can be easily cleaned off with a cloth moistened in vinegar. Remove any burnt-on residues after cooking; then rinse with water and dry thoroughly with a clean cloth. Changes in colour do not affect the operation and stability of the glass. These are not alterations to the

material of the hob but just residues which have not been removed and have then carbonised. Shiny surfaces can form due to the use of inappropriate cleaning products. They are difficult to remove using conventional cleaning products. It may be necessary to repeat the cleaning process several times. Using harsh detergents can wear away the decoration on the hob over time and contribute to the formation of stains.

 We recommend the use of cleaning products distributed by the manufacturer.

 After cleaning, dry the appliance thoroughly to prevent any water or detergent from interfering with its operation or creating unsightly marks.

### What to do if...

The hob does not work:

- Make sure that the hob is connected and that the main switch is turned on.

- Make sure that there is no power failure.
- Make sure that the fuse has not blown. In this case replace the fuse.
- Make sure that the circuit breaker of the residential electrical system has not tripped. In this case, reset the circuit breaker.

The cooking results are unsatisfactory:

- Make sure that the hob is properly ventilated and that the air inlets are unobstructed.

The hob smokes:

- Let the hob cool down and clean it once cooking is complete.
- Make sure that the food has not spilled out of the pan and use a larger cooking vessel, if needed.

The fuses blow or the circuit breaker of the residential electrical system trips repeatedly.

- Call Technical Support or an electrician.

There are cracks or fissures in the hob:

- Turn off the appliance immediately, disconnect the power supply and contact Technical Support.

## INSTALLATION

 The appliance must be installed by a qualified technician and according to the regulations in force.

 Appliance factory set for gas: NG pressure 1kPa.

### Gas connection

 See General safety instructions.

#### General information

This appliance is suitable for use with natural gas or ULPG (propane / butane) systems. Refer to the "Burner and nozzle characteristics table" section for information regarding the appropriate burner pressure and injector size. If the appliance is to be connected to natural gas, the pressure regulator must be fitted to the gas inlet. A test point (for checking the gas pressure) is supplied with the regulator, or as a separate fitting for ULPG (propane) appliances. The connection of the appliance to the gas supply must comply with the requirements of

AS5601.1. A 1/2" BSP connector at the inlet is recommended. The gas supply line to the appliance must be of an adequate length to allow it to be withdrawn sufficiently for maintenance or disconnection. It must also be:

- 1 an annealed copper pipe, or:
- 2 a 10 mm diameter Class "B" hose compliant with AS/NZ1869.

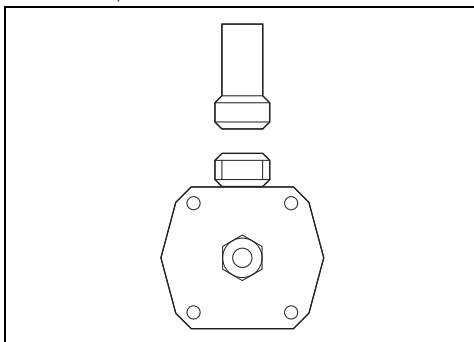

The appliance should be installed in such a way to allow the gas to be turned off and disconnected for maintenance and the removal of the appliance as necessary from the gas supply.

Before putting the appliance into operation, make sure that all the relevant parts are positioned correctly.

After installation, the installer **MUST** check for gas leaks and test each burner individually to make sure that the flame is correct. Once all the burners have been tested individually, light them all together.

The assistance service does not cover these adjustments!

It is recommended that at least 2 large burners be used to check the operating pressure of the appliance. Make sure the appliance is fixed to the wall after installation.

**Natural gas:** The regulator must be fitted to the 1/2" BSP thread on the back of the appliance. An approved manual shut-off valve must be installed. The natural gas regulator must be checked and adjusted to 1.0 kPa after installation.

**ULPG:** Can be connected directly to the inlet fitting. The pressure should be checked and, if necessary, adjusted to 2.75 kPa. A test point must be installed between the piping and the appliance to check that the pressure is 2.75 kPa.

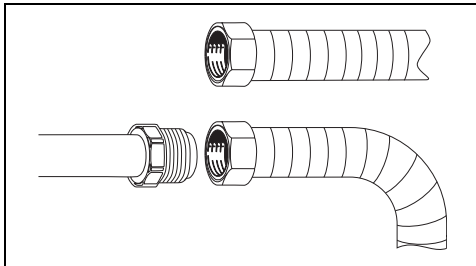

ULPG The gas pressure should be checked to make sure that the working pressure of the appliance is 2.75 kPa. The test point is the rapid burner injector, as shown below.

1. Disconnect the power.
2. Turn on the auxiliary burner and set it to high flame. Make sure that all the other burners are turned off.
3. Set the pressure gauge to zero, attach the hose in order to seal the rapid burner injector; hold firmly in place and check the gas pressure by pressing the corresponding burner control knob and then turn it to the high flame position.
4. If the pressure is 2.75 kPa, put back the burner and carry out the final checks as indicated in this instructions manual.

5. If the pressure is not 2.75 kPa, disconnect the appliance and check/adjust/replace the regulator(s) of the LPG cylinder in accordance with AS/NZS 5601.1.

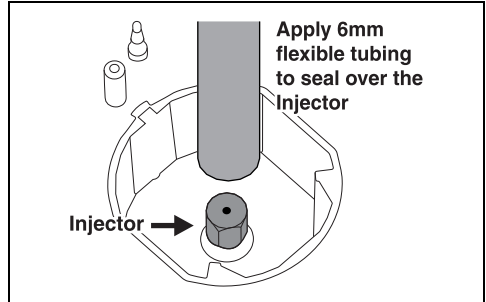

### Connection to LPG

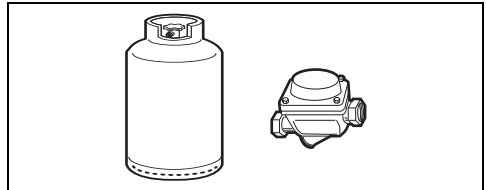

Use a pressure regulator and make the connection on the gas cylinder following the guidelines set out in the standards in force.

The supply pressure must comply with the values indicated in the "Burner and nozzle characteristics table".

### Removing the hob top

1. Remove the pan support grids from the hob.

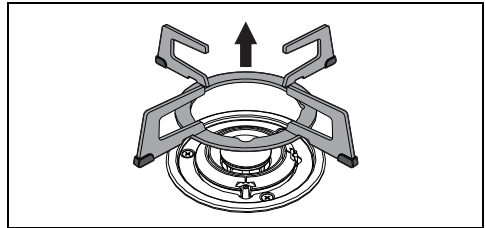

- Remove the flame-spreader crowns and relative burner caps.

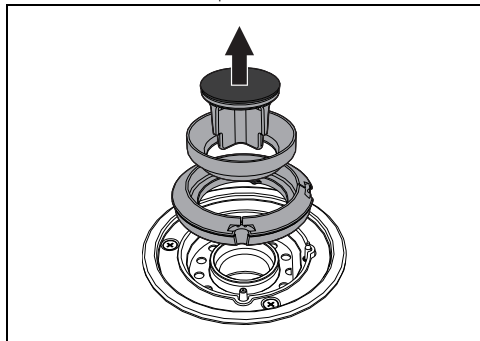

- Pull the knobs and the knob bezels upwards to remove them.
- For each burner, unscrew the screws that fix the fastening plates to the hob top.

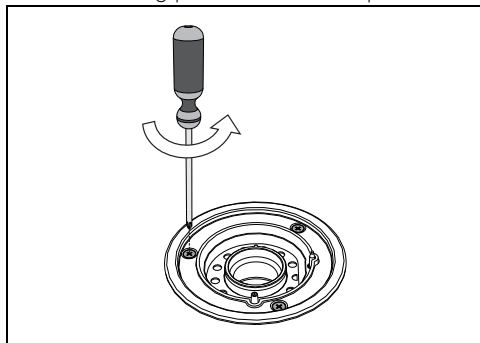

- Remove the screws that fasten the hob top to the burner casing (the figure shows the 60 cm model as an example. Burner) for each burner.

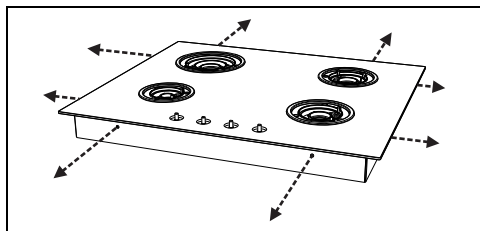

- Lift the hob top and remove it.

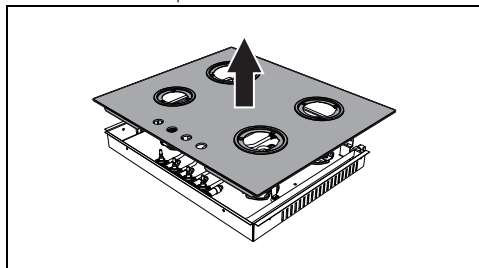

## Replacing nozzles

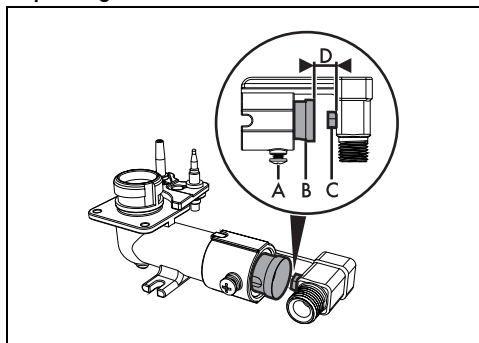

- Loosen the screw A and push the air regulator B as far as it will go.
- Use a spanner to remove the nozzles C and install the new ones for the required gas supply, following the indications given in the relevant tables (see "Gas types and countries").
- Adjust the air flow by moving the air regulator B to obtain the distance D given in the corresponding table (see "Gas types and countries").
- After adjusting each burner, reassemble the appliance correctly.



The maximum tightening torque must not exceed 3 Nm.

## Adaptation to different types of gas

In case of operation with other types of gas, the burner nozzles must be changed and the minimum flame adjusted on the gas cocks.

## Adjusting the minimum setting for natural gas

- Light the burner and turn it to the minimum position.
- Remove the gas tap knob and turn the adjustment screw next to the gas cock

spindle (depending on the model) until the correct minimum flame is achieved.

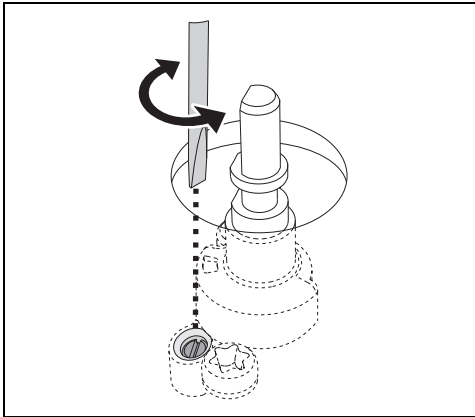

3. Refit the knob and verify that the burner flame is stable.
4. Turn the knob rapidly from the maximum to the minimum setting: The flame should not go out.
5. Repeat the operation on all the gas taps.

### Adjusting the minimum setting for LPG

Tighten the screw located at the side of the cock

spindle clockwise all the way.



Following adjustment to a gas other than the one originally set in the factory, replace the gas setting label on the appliance with the one corresponding to the new gas. The label is inserted inside the nozzle pack (where present).

### Lubricating the gas cocks

Over time the gas cocks may become difficult to turn and get blocked. Clean them internally and replace the lubrication grease.



Lubrication of the gas cocks should be performed by a specialised technician.

### Room ventilation

The appliance should be installed in rooms that have a permanent air supply in accordance with the standards in force. The room where the appliance is installed must have enough air flow for the regular combustion of gas and the necessary air change in the room itself. The air vents, protected by grilles, must be the right size to comply with current regulations and positioned so that no part of them is obstructed, not even partially.

The room must be kept adequately ventilated in order to eliminate the heat and humidity produced by cooking: In particular, after prolonged use, you are recommended to open a window or to increase the speed of any fans.

### Burner and nozzle characteristics tables

NG 1.0 kPa	AUX	SR	RR	R	UR
Nominal gas consumption (MJ/h)	4.0	6.1	9.0	10.4	12.6
Nozzle diameter (1/100 mm)	0.85	1.10	1.32	1.45	1.60
Primary air (mm)	4	4	4	4	4
ULPG 2.75 kPa	AUX	SR	RR	R	UR
Nominal gas consumption (MJ/h)	4.0	6.5	9.0	10.4	12.6
Nozzle diameter (1/100 mm)	0.54	68	0.80	0.85	0.93
Primary air (mm)	10	10	10	10	10

The nozzles not provided are available at Authorised Service Centres.

### Electrical connection



See General safety instructions.

### General information

Check the mains characteristics against the data indicated on the plate.

The identification plate bearing the technical

data, serial number and brand name is visibly positioned on the appliance.

Do not remove this plate for any reason.

The appliance must be connected to ground using a wire that is at least 20 mm longer than the other wires.

The appliance can work in the following modes:

- 220-240 V 1N<sup>~</sup>

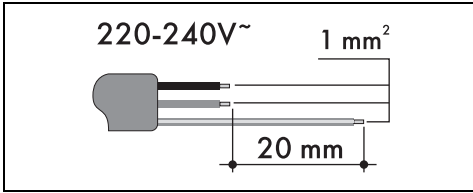

 The values indicated refer to the cross-section of the internal conductor.

 The aforementioned power cables are sized taking into account the coincidence factor (in compliance with standard EN 60335-2-6).

### Fixed connection

Fit the power line with an all-pole circuit breaker with a contact separation distance sufficient to provide complete disconnection in category III overvoltage conditions, pursuant to installation regulations.

### For the Australian/New Zealand market:

The circuit breaker incorporated in the fixed connection must comply with AS/NZS 3000.

### Section cut from the countertop

### Safety instructions for positioning and installation

 See General safety instructions.

- Installation can be carried out on various materials such as masonry, metal, solid wood or plastic laminated wood as long as they are heat resistant (>90°C).
- Veneers, adhesives or plastic coatings on adjacent furniture should be temperature-resistant (>90°C), otherwise they might warp over time.
- If the piece of furniture does not have the required recess opening, either it will have to be cut or masonry work carried out by a competent technician.
- The minimum clearance between exhaust hoods and the cooking surface must be at least the distance indicated in the exhaust hood installation instructions.
- The minimum clearances must also be respected for the edges of the hob on the back as indicated in the assembly

instructions.

- If the appliance is to be installed above an oven, the oven must be fitted with a cooling fan.

### Appliance overall dimensions (mm)

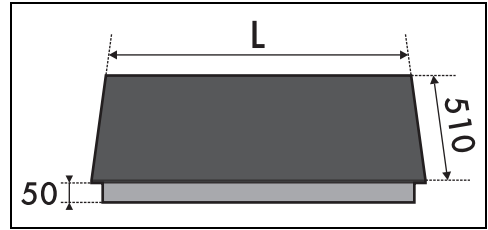

	L
Models A 60 cm	600
Models B 75 cm	750
Models C 100 cm	1000

### Built-in cabinet dimensions (mm)

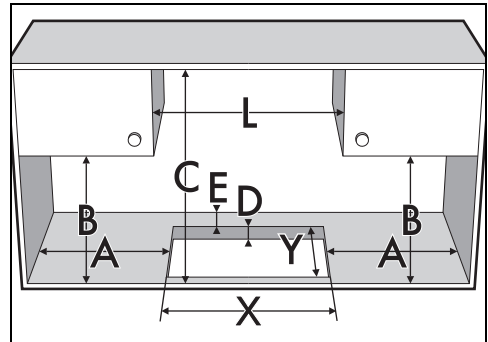

L (mm)	X (mm)	Y (mm)
600	560 - 564	482 - 486
750	700 - 704	482 - 486
1000	880 - 884	482 - 486

A (mm)	B (mm)	C (mm)*	D (mm)	E (mm)
min 200	min 460	min 750	40 - 60	min 50

\*If there is a kitchen unit positioned above the hob. In the case of a hood, refer to the measurements indicated in the relative manual.

### Hob seal

To prevent leakage of liquid between the frame of the hob and the countertop, place the adhesive seal provided along the entire outer

edge of the hob before assembly.

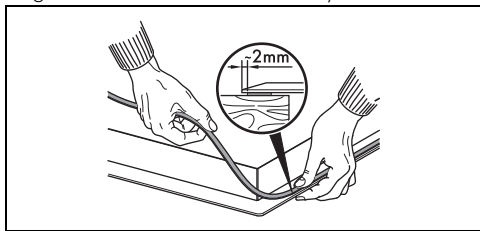

**!** Do not use silicone to secure the hob. This would make it impossible to remove the hob without damaging it.

### Fastening to the built-in cabinet

To prevent leakage of liquid between the frame of the hob and the countertop, place the adhesive seal provided along the entire outer edge of the hob before assembly.

1. Refer to the dimensions indicated in the figure, bearing in mind that the long front and rear sides must be flush with the hole.

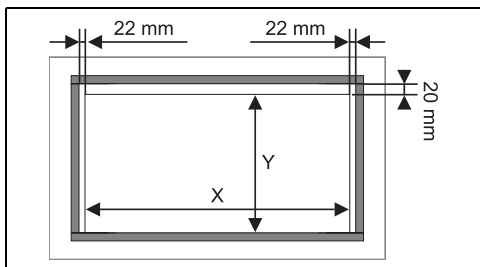

2. Press lightly to make the seal stick to the edge around the hole in the worktop. The front and rear sides of the seal must be flush with the hole.
3. Carefully trim the excess away from the edge of the seal.

**!** Do not use silicone to secure the hob. This would make it impossible to remove the hob without damaging it.

### Mounting

#### Over built-in oven unit

The clearance between the hob and the kitchen units or other built-in appliances must be enough to ensure sufficient ventilation and air discharge. If installed above an oven, a space must be left between the bottom of the hob and the top of

the appliance installed below.

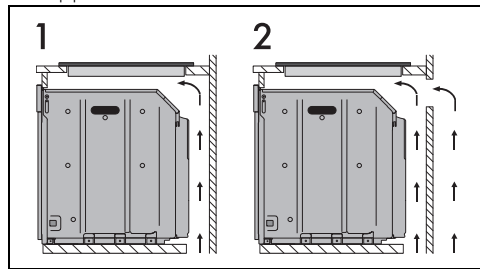

- 1 Opens on bottom
- 2 Opens on bottom and back

#### On top of an empty kitchen unit or drawers

If there are other pieces of furniture (lateral walls,

drawers etc.), dishwashers or fridges under the hob, a double-layer wooden base has to be installed at least 20 mm from the bottom of the hob to avoid any accidental contact. It must only be possible to remove the double-layer base by using suitable tools. (\*necessary for gas connection).

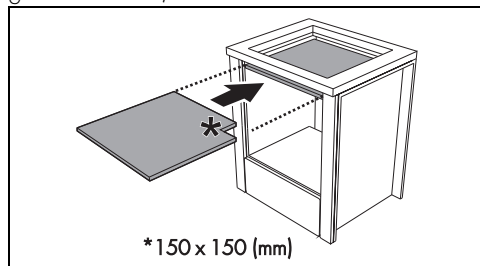

\*necessary for gas connection

With opening on bottom or back:

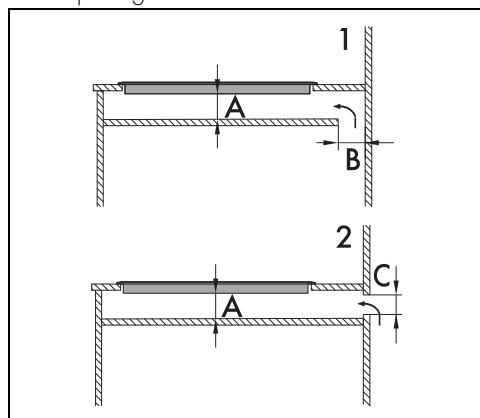



- 1 Opens on bottom
- 2 Opens on back
- A min. 20 mm - max. 50 mm
- B max. 50 mm
- C max. 50 mm



Failure to install the double-layer wooden base exposes the user to possible accidental contact with sharp or hot parts.



If installed on top of an oven, the latter must be equipped with a cooling fan.

### Fixing to the built-in cabinet

In order to ensure fixing to the built-in cabinet and optimum centring, the supplied fixing brackets must be screwed into the holes in the bottom casing.

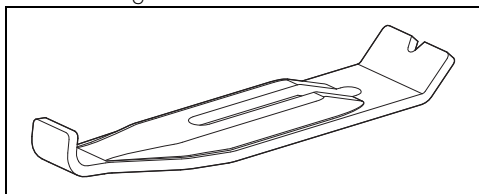

Screw the fixing brackets into the dedicated holes to properly fasten the hob to the built-in structure.

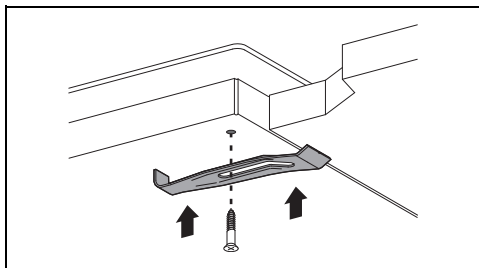

### Instructions for the installer

- If you use a plug to connect to the power supply, the plug must be accessible after installation.
- Do not bend or trap the power cable.
- The appliance must be installed according to the installation diagrams.
- Do not try to unscrew or force the threaded elbow of the fitting. You may damage this part of the appliance, which may void the manufacturer's warranty.
- Use soap and water to check for gas leaks

on all connections. DO NOT use naked flames to search for leaks.

- Turn on all the burners separately and at then all together to make sure that the gas valve, burner and ignition are working properly.
- Turn the burner knobs to the minimum position and check that the flame is stable for each individual burner and all the burners together.
- If the appliance does not work correctly after having carried out all the checks, contact your local Authorised Service Centre.
- Once the appliance has been installed, please explain to the user how to use it correctly.