

USER MANUAL  
COFFEE GRINDER

EN

MANUEL DE L'UTILISATEUR  
MOULIN À CAFÉ

FR

MANUAL DE USO  
MOLINILLO DE CAFÉ

ES



We advise you to read this manual carefully, as it contains all the instructions for managing the appliance's aesthetic and functional qualities.

For further information on the product: [www.smegusa.com](http://www.smegusa.com)

Nous conseillons de lire attentivement ce manuel, qui comprend toutes les indications pour maintenir inaltérées les qualités esthétiques et fonctionnelles de l'appareil acheté.

Pour obtenir des informations supplémentaires sur le produit : [www.smegusa.com](http://www.smegusa.com)

Aconsejamos leer atentamente este manual que contienen todas las indicaciones para mantener inalterada la calidad estética y funcional del aparato adquirido.

Más información sobre el producto en: [www.smegusa.com](http://www.smegusa.com)

"A"

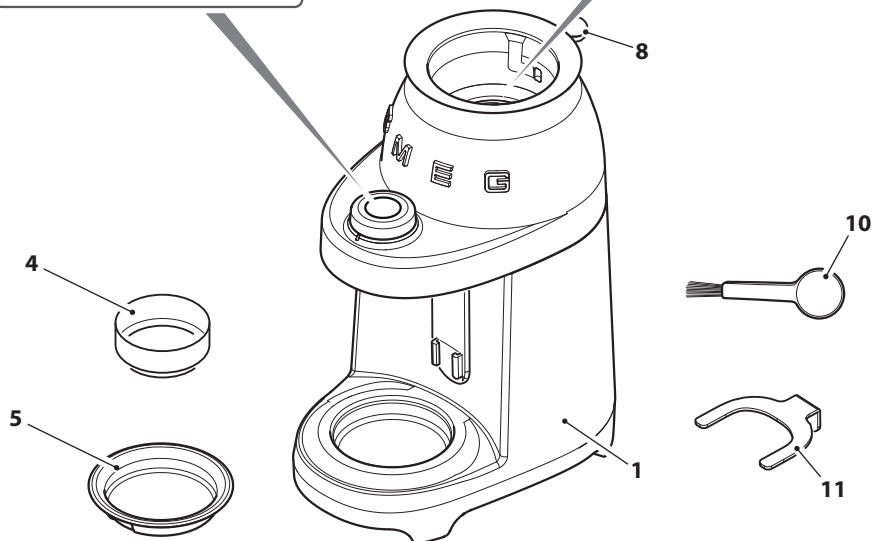
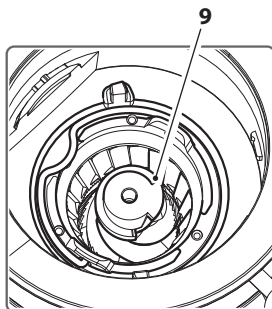
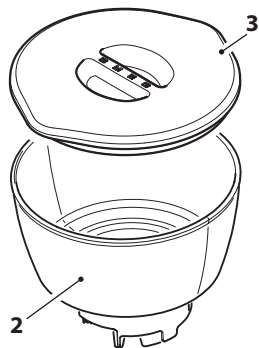
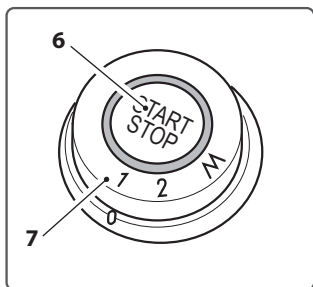

"B"

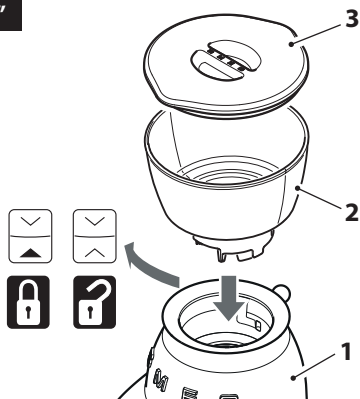

"C"

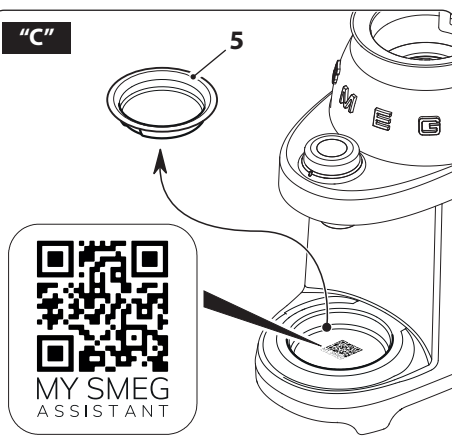

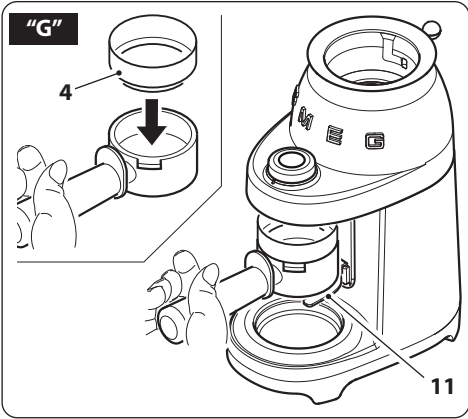
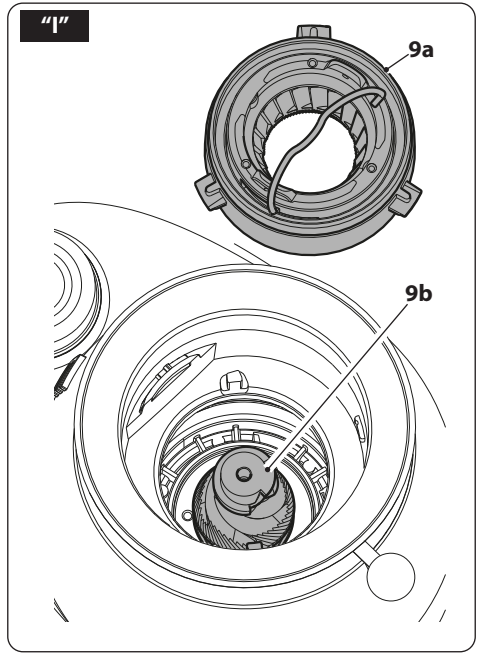
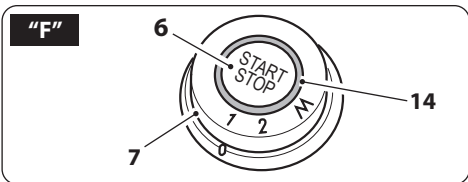
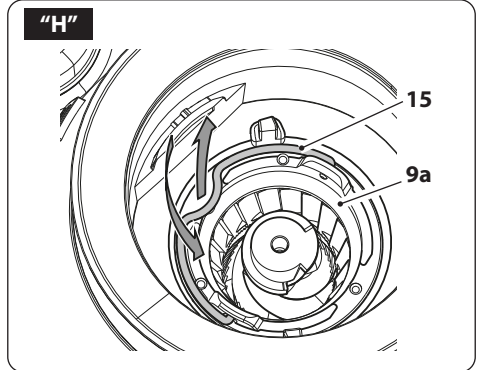
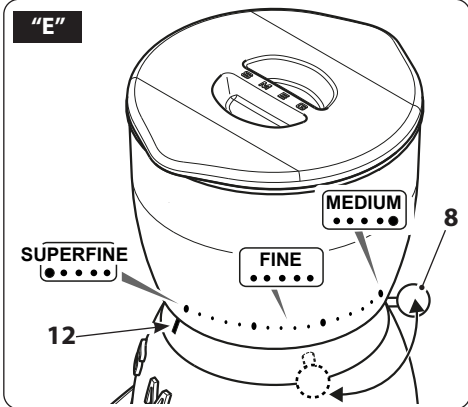
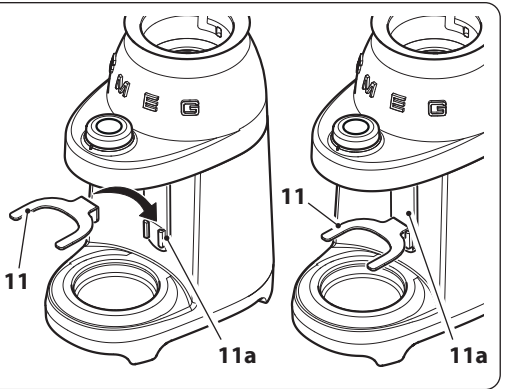
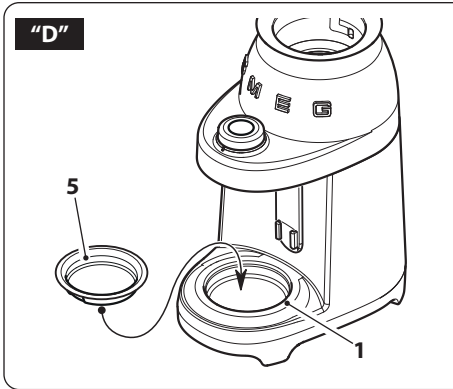

**Important information for the user**  
**Informations importantes pour l'utilisateur**  
**Información importante para el usuario**

 **Instructions / Instructions / Instrucciones**

 **Description / Description / Descripción**

 **Use / Utilisation / Uso**

 **Cleaning and care / Nettoyage et entretien / Limpieza y cuidado**

 **Safety instructions / Consignes de sécurité / Instrucciones de seguridad**

 **Information / Informations / Información**

 **Advice / Conseil / Recomendaciones**

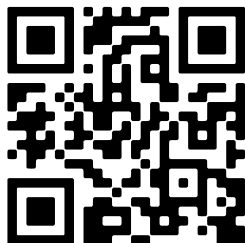

Scan the QR code for a quick access to the portal My Smeg Assistant  
Scannez le code QR pour accéder rapidement au portail My Smeg Assistant  
Escanee el código QR para acceder rápidamente al portal My Smeg Assistant

**MY SMEG**  
ASSISTANT

The manufacturer reserves the right to make any changes deemed useful for the improvement of its products without prior notice. The illustrations and descriptions contained in this manual are therefore not binding and are merely indicative.

Le fabricant se réserve la faculté d'apporter, sans préavis, toutes les modifications qu'il jugera utiles pour l'amélioration de ses produits. Les illustrations et les descriptions figurant dans ce manuel ne sont pas contraignantes et n'ont qu'une valeur indicative.

El fabricante se reserva el derecho a aportar sin aviso previo todas las modificaciones que considere útiles para la mejora de sus propios productos. Las ilustraciones y las descripciones contenidas en este manual no comprometen, por tanto, al fabricante y tienen un valor meramente indicativo.



# Important instructions

## Important instructions



**WARNING:** If the instructions contained in this manual are not followed precisely, fire or explosion may result causing property damage, personal injury or death.



### **READ AND SAVE THESE INSTRUCTIONS**

Your safety and the safety of others are very important.

We have provided many important safety messages throughout this manual and on the appliance.

Read all the instructions before using the appliance and always obey all safety messages.

### **WARNING**



- **To reduce the risk of fire or electric shock, do not remove the cover (or back).**
- **No user-serviceable parts inside!**
- **Repair should be done by authorized service personnel only.**



### **RECOGNIZE SAFETY INFORMATION**

This is a safety alert symbol. This symbol alerts you to potential hazards that can result in severe personal injury or death.

### **UNDERSTAND SIGNAL WORDS**

A signal word - DANGER, WARNING or CAUTION - is used with the safety alert symbol. DANGER denotes the most serious hazards. It means you could be killed or seriously injured if you do not immediately follow the instructions.

WARNING means you could be killed or seriously injured if the instructions are not followed. CAUTION indicates a potentially hazardous situation, which, if not avoided, could result in minor to moderate injury.

# Important instructions



## ATTENTION



- This appliance is intended for use in the home only.
- Use this appliance only for its intended purpose. The manufacturer cannot be held liable for damage caused by improper use of this appliance.
- This appliance complies with current safety regulations. Improper use of this appliance can result in personal injury and material damage.
- Read all the instructions before installing or using the appliance for the first time.
- Keep these operating instructions in a safe place and pass them on to any future user.

The safety messages will inform you of potential hazards, on how to avoid the risk of injury and what can occur if the instructions are not followed.

**IMPORTANT: Observe all codes and ordinances in force.**

**WARNING: For your safety, the instructions contained in this manual must be followed to minimize the risk of fire or explosion and to prevent property damage, personal injury or death.**

Do not store or use gasoline or other flammable vapors, liquids or materials near this or any other appliance.



**NOTE:** This appliance is NOT designed for installation in manufactured (mobile) homes or in recreational vehicles (RVs).



### **NOTE:**

**POLARIZED PLUG** (for product manufactured with polarized plug)

This appliance has a polarized plug (one blade is wider than the other).

To reduce the risk of electric shock, this plug is designed to fit into a polarized outlet only one way. If the plug does not fit fully into the outlet, flip it over and try again. If it still does not fit, contact a qualified electrician. Do not modify the plug in any way.

**GROUNDING PLUG** (for product manufactured with a grounded plug)

As a safety feature, this product is equipped with grounded plug, which will only fit into a three-prong outlet. Do not attempt to bypass this safety feature. Improper connection of the grounding conductor may result in the risk of electric shock. Consult a qualified electrician if you have any doubts on whether the outlet is properly grounded.





# Important Safeguards

**WARNING** When using electrical appliances, basic safety precautions should always be followed to reduce the risk of fire, electric shock, and / or injury to person including the following:



Follow all safety precautions to ensure safe use of the appliance.

- Before using the appliance, read this user manual carefully.
- Do not use the appliance outdoors.
- This appliance is for household use only.
- Do not use the appliance for other than its intended use.
- Do not allow children to use the appliance.
- Children should not play with the appliance. Keep the appliance out of the reach of children.
- Keep the packaging material (plastic bags, expanded polystyrene) out of the reach of children.
- Close supervision is necessary when any appliance is used by or near children.
- Turn off the appliance immediately after use.
- Do not leave the appliance unattended while it is running.
- Disconnect the appliance from the wall outlet before assembly, disassembly, cleaning and after each use.
- To disconnect, turn any control to the off position, then remove plug from wall outlet.
- Unplug from outlet when the appliance is not in use, and before cleaning. Allow to cool before putting on or taking off parts, and before cleaning the appliance.
- Do not use appliance for other than intended use.
- To protect against fire, electrical shock and personal injury, do not immerse the appliance, the power cord or plug in water or any other liquid.
- Do not touch the appliance or the plug with wet hands.
- Never try to extinguish a flame/fire with water: turn off the appliance, unplug it from the outlet and cover the flame with a lid or a fire blanket.
- Do not use the appliance if the power cord or plug is damaged or if the appliance has been dropped or damaged in any way.
- Do not let cord hang over edge of table or counter, or touch hot surfaces.
- Do not operate any appliance with a damaged cord or plug or after the appliance malfunctions, or has been damaged in any manner. Return appliance to an authorized service facility for examination, repair or adjustment.
- Make sure the power cord does not come in contact with sharp edges.
- Do not pull on the cord to remove the plug from the socket.
- Do not place the appliance on or near switched-on gas or electric burners, inside an oven, or near heat sources.

## SAVE THESE INSTRUCTIONS

# Important Safeguards



- Do not touch hot surfaces. Use handles and knobs.
- Do not place the appliance near faucets or sinks.
- Never attempt to repair the appliance yourself or without the help of a qualified technician. Failing to do this will void the warranty.
- In case of malfunction, have the appliance repaired by a qualified technician.
- Do not make any changes to the appliance.
- Make sure that the power outlet used is always freely accessible, because only in this way can it be unplugged when necessary.
- To remove the plug from the power outlet, operate directly on the plug. Never pull the cable, it could be damaged.
- If the appliance should break down, do not attempt to repair it.
- Do not allow the power supply cable to dangle over the edge of the table or other surface or to touch hot surfaces.
- If the plug or power supply cable are damaged, have them replaced exclusively by the Technical After-sales centre, so as to prevent all risks.

## For this appliance

- Do not use the appliance for more than 90 seconds consecutively. Leave the appliance to cool down for a few minutes before using it again.
- The appliance shall not be placed in a cabinet when in use.
- Leave a space of 10 cm around the appliance.
- Make sure the lid is firmly closed.
- Do not open the lid during the grinding.
- Do not use the appliance in combination with parts or accessories from other manufacturers.
- Use only original spare parts from the manufacturer. The use of spare parts not recommended by the manufacturer may cause fire, electric shock or injury to persons.
- Place the appliance on a flat, dry surface.
- Avoid wetting or spraying liquid on the appliance. In case of contact with liquid, immediately unplug the cord from the electrical outlet and dry thoroughly: Risk of electric shock!
- Do not use abrasive cleaners or sharp objects to clean the appliance.
- The use of an accessory not evaluated for use with this appliance may cause injuries.
- Do not install the appliance in an environment that is not suitable.
- Do not place the appliance on or in proximity of electric or gas cookers, or in a heated oven.

## SAVE THESE INSTRUCTIONS



# Important Safeguards

- Verify that there are no foreign objects inside the coffee grinder.
  - This appliance is not intended for use by persons (including children) with reduced physical, sensory, or mental capabilities, or lack of experience and knowledge, unless they are closely supervised and instructed concerning use of the appliance by a person responsible for their safety. Children should be supervised to ensure that they do not play with the appliance.
  - Avoid contacting moving parts.
  - Check hopper for presence of foreign objects before using.
  - This appliance has important markings on the plug blade. Contact a qualified technician to replace the plug with a suitable one if damaged.
  - Connect the appliance only to a power outlet installed perfectly.
  - Furthermore, it can not be used:
    - in the kitchen area for employees of shops, in offices or other work environments;
    - in farms/farm holiday complexes;
    - by customers in hotels, motels and residential environments;
    - in bed and breakfast accommodation.
1. The marked electrical rating of the detachable power-supply cord or extension cord should be at least as great as the electrical rating of the appliance;
  2. If the appliance is of the grounded type, the extension cord should be a grounding-type 3-wire cord; and
  3. The longer cord should be arranged so that it will not drape over the counter top or table top where it can be pulled on by children or tripped over.

## Connect the appliance

Make sure that the mains voltage corresponds with that indicated on the data plate on the bottom of the appliance.

Connect the appliance only to a power outlet installed perfectly.

If the plug and power outlet are incompatible, have the power outlet replaced with a suitable type by qualified staff.

## Electrical Cord:

- a) A short power-supply cord (or detachable power-supply cord) is provided to reduce risks resulting from becoming entangled in or tripping over a longer cord.
- b) Longer detachable power-supply cords or extension cords are available and may be used if care is exercised in their use.
- c) If a long detachable power-supply cord or extension cord is used:

# SAVE THESE INSTRUCTIONS

# Important Instructions



## This user's manual

This user's manual is an integral part of the appliance and must be kept intact and available to the user throughout its life cycle.

## Use compliant with destination

This appliance is intended for domestic use only.

Furthermore, it can not be used:

- in the kitchen area for employees of shops, in offices or other work environments;
- in farms/farm holiday complexes;
- by customers in hotels, motels and residential environments;
- in bed and breakfast accommodation.

## Manufacturer's liability

The manufacturer declines all liability for damage undergone by persons and objects due to:

- use of the appliance different from that envisioned;
- user manual has not been read;
- tampering of individual parts of the appliance;
- use of non-original spare parts;
- failure to comply with safety recommendations.

## Identification plate

The identification plate lists the technical data, serial number and brand name. The identification plate must never be removed.

## Disposal



Power voltage  
Risk of electric shock

- Unplug the appliance.
- Unplug the cord from the wall outlet.

## • Old electrical equipment must not be disposed of with household waste!

In accordance with the law in force, electrical appliances at the end of their life should be taken to separate collection facilities for electrical and electronic waste. This is so that valuable materials from old appliances can be recycled and the environment can be protected. For more information, please contact your local authorities or recycling center employees.

Note that non-polluting and recyclable materials are used for packaging the appliance.

- Dispose of the packaging materials at appropriate differentiated waste collection centers.



Plastic packaging  
Risk of suffocation

- Do not leave the packaging or any part of it unattended.
- Do not allow children to play with the plastic packaging bags.



## APPLIANCE DESCRIPTION

### (Fig. A)

- 1 Motor base
- 2 Coffee bean container (240 g)
- 3 Coffee bean container lid
- 4 Dosing ring Ø 58mm
- 5 Container support plate
- 6 START/STOP button
- 7 Grinding functions selection knob
- 8 Grinding level adjustment lever
- 9 Grinder
- 10 Cleaning brush
- 11 Filter-holder support fork

## IDENTIFICATION

### PLATE

The identification plate states the technical data, serial number, and marking. The identification plate must never be removed.

## BEFORE COMMISSIONING

### (Fig. A)

- Unpack the appliance carefully and remove all packaging materials and promotional labels.
- Wash all components, except for the motor base (1) and the grinder (9), with hot water and normal washing-up liquid. Rinse all components thoroughly and dry them before use.



The grinder must never be washed and must always be kept dry. Clean the grinder with the cleaning brush provided or with a hard-bristle brush.



Before use, check that all the components are integral and do not have any cracks.

## ASSEMBLY OF COMPONENTS

### (Fig. B-C-D)

- Position the container (2) on the motor base (1) matching up the two reference notches "∨" "∧" on the left side of the motor body (1).  
Now, rotate the container (2) clockwise until the two indications "∨" "▲" match.
- Position the lid (3) on the container (2) and press it down.
- Position the plate (5) on the motor base (1) in a way to secure it.
- Position the filter-holder support fork (11) in the relative housing (11a).

## DESCRIPTION OF CONTROLS

### (Fig. E-F)

#### Grinding adjustment lever (8)

The appliance has a lever (8), which allows the level of grinding to be adjusted appropriately to your use:

<b>SUPERFINE</b>	Superfine grinding
<b>FINE</b>	Fine grinding
<b>MEDIUM</b>	Medium grinding

Move the lever to make the indicator (12) correspond with the desired grinding level.



For use with EMC02 coffee machines, it is advised to adjust the coffee grinder to the "SUPERFINE" setting.



# Controls/Use

## Quantity of grinding selection knob (7)

The appliance has 2 pre-set functions and a manual function, which can be selected using the knob (7).

Each function corresponds to a predefined quantity of ground coffee.

Knob icon	Quantity
<b>1</b>	Grinding for Single espresso
<b>2</b>	Grinding for Double espresso
<b>M</b>	Manual Function

The Manual function (M) can be used at will with any level of grinding.

## USE (Fig. A-E-F-G)



Make sure the upper grinder (9A) is inserted and secured in its housing.

- Insert the plug into the power outlet.
- Lift the lid (3) and introduce the coffee beans into the container (2).



If the LED located on the knob flashes, it means that the appliance is in error condition: beans container not present or not inserted correctly.



Coffee may lose flavour quickly once ground. For excellent results, use coffee powder immediately after grinding. Store the ground coffee container in a dark, cool and dry environment. Make sure the coffee powder level is lower than the container maximum level mark and that the container lid is closed well and screwed on tightly.

## Grinding the coffee in to the espresso coffee filter-holder (Fig.D-F-G)

- If the dosing ring (58mm) is to be used, position it on the compatible filter holder.
- Position the filter-holder support fork (11) in the relative attachment (11a).
- Position the filter-holder under the dispensing cone.
- Select the grinding level.
- Select program "1" or program "2" according to the function desired.
- Press the START/STOP button (6) to start grinding. For all pre-set programs, grinding will end automatically.
- When grinding has been completed, remove the filter-holder.



The dosing ring (4) prevents the coffee powder from falling, thus helping to reduce dirtying and waste. Compatible with Smeg 58 mm filter-holders.



Filter-holder not supplied.



If the manual grinding operating time exceeds the safety time set (90 seconds), the motor stops automatically.



During the grinding phase, do not turn the knob (7) from one program to another and do not move the grain selection lever (8).



If a finer level of grinding than that currently used is to be set, it is highly recommended to remove the grinder and clean it to remove any residual beans, before proceeding with a new grinding operation. See the **CLEANING AND MAINTENANCE** section to remove the grinder.



A beans locking system allows the container (2) to be raised safely from the motor base (1), in a way to prevent the beans escaping.



The coffee grinder has an auto-off function (stand-by), in the event it is not used after 90 seconds. Press the **START/STOP** button to re-activate the product.

## GRINDING TIMES (Fig. E-F)

The functions envision pre-set ground coffee supply settings. However, depending on personal taste, the pre-set amount of ground coffee can be increased or decreased, thus customising the different functions.

## Customise the amount of grinding for espresso coffee

- Make sure that the grinding indicator (12) is positioned at an adequate grinding level for espresso coffee (SUPERFINE).
- Turn the knob (7) to "1".
- Press the **START/STOP** button (6) to start grinding and hold it down for the desired time; the ring (14) flashes during the programming phase.
- On releasing the button, grinding stops, the ring stops flashing and the new setting is memorised.



Repeat the same procedure to customise the amount of grinding for a double espresso by turning the knob (7) to "2".

## Restoring factory values

To reset the factory values:

- Turn the knob (7) to program "M".
- Press the **START/STOP** button (6) and hold it down for 5 seconds. The ring (14) flashes 5 times indicating that all factory-set values have been reset.

## CLEANING AND MAINTENANCE (Fig. A-H-I)

- Make sure the coffee bean container (2) is empty and then activate manual mode (M) to remove any coffee residues from the grinder.





# Cleaning and maintenance



## What To Do If.....

Problem	Possible causes	Solution
The appliance does not work.	Unplugged.	Plug in.
	The coffee bean container is not inserted correctly.	Check that the coffee bean container is correctly inserted in the motor base.
The led on the knob flashes.	The motor thermal protection has activated automatically.	Wait (approx. 30 minutes) for the thermal protection to reset.
	The coffee bean container is not inserted correctly.	Check that the coffee bean container is correctly inserted in the motor base. See the Assembly of Components paragraph to assemble the container.
The appliance stops during operation.	The motor thermal protection has activated automatically.	Wait (approx. 30 minutes) for the thermal protection to reset.



## Cleaning and maintenance

Problem	Possible causes	Solution
The appliance works but does not dispense ground coffee.	No coffee beans in the relative container.	Load the coffee beans.
	Grinder blocked.	Remove the grinder and check there are no objects blocking rotation.
The grinding level set is incorrect or difficult.	The top of the grinder (9a) is missing.	Insert and secure the upper grinder (9a) in its housing.
	Grinders worn.	Replace the grinders by taking the appliance to an authorised after-sales centre.



Contact local technical support if the problem is not solved or in case of other types of faults.