

Dear Customer,

*Thank you for choosing this special edition Smeg – Dolce&Gabbana,
Sicily is my love small domestic appliance.*

*Smeg and Dolce&Gabbana have combined their artistic talents to create a unique
collection, made in Italy by Smeg with unmistakable Dolce&Gabbana design touches.*

We hope you enjoy using your new appliance!

Kindest regards,

SMEG S.p.A.

1 Instructions	9
1.1 Introduction	9
1.2 This user manual	9
1.3 Intended use	9
1.4 Manufacturer liability	10
1.5 Identification plate	10
1.6 Disposal	10
2 Description	11
2.1 Product description	11
2.2 Description of parts	12
2.3 Standard accessories	13
3 Use	15
3.1 Before first use	15
3.2 Using the stand mixer	16
3.3 Using the pouring shield	21
3.4 Functions	22
3.5 Speed setting suggestions	23
4 Cleaning and Care	27
4.1 Instructions	27
4.2 Maintenance	27
4.3 Ordinary daily cleaning	27
4.4 What to do if...	28

Important Safeguards

WARNING: If the instructions contained in this manual are not followed precisely, fire or explosion may result causing property damage, personal injury or death.



READ AND SAVE THESE INSTRUCTIONS - Your safety and the safety of others are very important.

We have provided many important safety messages throughout this manual and on the appliance.

Read all the instructions before using the appliance and always obey all safety messages.



Important Safeguards



RECOGNIZE SAFETY INFORMATION

This is a safety alert symbol. This symbol alerts you to potential hazards that can result in severe personal injury or death.

UNDERSTAND SIGNAL WORDS

A signal word - DANGER, WARNING or CAUTION - is used with the safety alert symbol. DANGER denotes the most serious hazards. It means you could be killed or seriously injured if you do not immediately follow the instructions.

WARNING means you could be killed or seriously injured if the instructions are not followed. CAUTION indicates a potentially hazardous situation, which, if not avoided, could result in minor to moderate injury.

WARNING



- **This appliance is intended for use in the home only.**
- **Use this appliance only for its intended purpose. The manufacturer cannot be held liable for damage caused by improper use of this appliance.**
- **This appliance complies with current safety regulations. Improper use of this appliance can result in personal injury and material damage.**
- **Read all the instructions before installing or using the appliance for the first time.**
- **Keep these operating instructions in a safe place and pass them on to any future user.**

The safety messages will inform you of potential hazards, on how to avoid the risk of injury and what can occur if the instructions are not followed.

IMPORTANT: Observe all codes and ordinances in force.

WARNING: For your safety, the instructions contained in this manual must be followed to minimize the risk of fire or explosion and to prevent property damage, personal injury or death.

Do not store or use gasoline or other flammable vapors, liquids or materials near this or any other appliance.



NOTE: This appliance is NOT designed for installation in manufactured (mobile) homes or in recreational vehicles (RVs).

DO NOT install this appliance outdoors.

Important Safeguards



WARNING



To reduce the risk of fire, electrical shock, personal injury, or damage when using the appliance, follow basic safety precautions, including the following:

Follow all safety instructions in order to use the appliance safely.

- Read this user manual carefully before using the appliance.
- To protect against electric shock, do not immerse the appliance, the power cord or the plug in water or any other liquid.
- Do not use the appliance when the power cord or the plug is damaged or after the appliance malfunctions, or when the appliance has fallen or is damaged in any manner. Return appliance to the nearest authorized service facility for examination, repair or adjustment.
- If the supply cord is damaged, it must be replaced by the manufacturer, its service agent or similarly qualified persons in order to avoid a hazard.
- The cable is short to prevent accidents. Do not use an extension cord.
- Do not let cord hang over edge of table or counter or touch hot surfaces.
- Do not pull on the cord to unplug it from the power socket.
- Do not place the appliance above or near lit cooktop burners or electric rings, inside an oven or near other heat sources.
- Switch off the appliance immediately after use.
- Do not leave the appliance unattended while it is operating.
- Disconnect the appliance from the power socket as soon as you have finished using it and before cleaning it.
- In case of fault repairs should only be carried out by a qualified technician.
- Never try to put out a fire or flames with water: turn off the appliance, remove the plug from the socket and smother the flames with a fire blanket or any other appropriate cover.
- Do not modify the appliance.
- Keep the appliance out of children's reach.



Important Safeguards

For this appliance

- Unplug the appliance from the power socket as soon as you have finished using it and before cleaning it.
- Always unplug the appliance from the wall if it is left unattended and before assembling, disassembling or cleaning.
- Remove beaters from mixer before washing.
- Do not use more than one attachment at a time.
- Do not insert, remove or replace attachments with the safety lock disengaged (motor head lowered).
- Do not touch moving parts while the appliance is operating. Keep hands, hair, clothing, spatulas and any other objects away from the mixer's attachments and accessories to avoid personal injury or damage to the appliance.
- Do not remove attachments while the mixer is operating. Switch off the appliance and unplug it before changing accessories or approaching parts that move are in use.
- Check that the bowl is correctly positioned and locked into its base before you start using the appliance with its attachments.
- Do not release or remove the bowl while the appliance is operating.
- Do not exceed the bowl's maximum capacity.
- Let the appliance cool down before cleaning.
- The use of attachments not recommended or sold by the manufacturer may cause fire, electric shock or injury.
- Do not place objects on top of the appliance.
- Do not use harsh detergents or sharp objects to wash or remove residues from the bowl, attachments or accessories.
- Do not use outdoors.
- The stand mixer can be used to mix, whip, whisk and knead solid and liquid ingredients to speed up the preparation time for various recipes. With the addition of optional accessories it is able to grind, mince, grate, mill, roll out and cut pasta into different shapes, etc.
- Close supervision is necessary when any appliance is used by or near children.

SAVE THESE INSTRUCTIONS

Important Safeguards



NE

1 Instructions

1.1 Introduction

Key information for the user:

Instructions



General information on this user manual, on safety and final disposal.

Description



Description of the appliance and its accessories.

Use



Information on the use of the appliance and its accessories, advice on preparing recipes with the appliance.

Cleaning and care



Information for correct cleaning and care of the appliance.



Safety instructions



Information



Advice

1.2 This user manual

This user manual is an integral part of the appliance and must therefore be kept in its entirety and within the user's reach for the whole working life of the appliance.

1.3 Intended use

- The appliance is designed exclusively for home use.
- Do not use the appliance for anything other than the intended use.
- Do not use outdoors.
- The stand mixer can be used to mix, whip, whisk and knead solid and liquid ingredients to speed up the preparation time for various recipes. With the addition of optional accessories it is able to roll out and cut pasta into different shapes.
- The appliance is not designed to operate with external timers or with remote-control systems.
- This appliance may not be used by people (including children) of reduced physical and mental capacity, or lacking in experience in the use of electrical appliances, unless they are supervised or instructed by adults who are responsible for their safety.

i The California Safe Drinking Water and Toxic Enforcement Act requires the Governor of California to publish a list of substances known to the State of California to cause cancer, birth defects or other reproductive harm, and requires businesses to warn customers of potential exposure to such substances.



Important Safeguards



Warning

- This product contains a chemical known by the State of California to cause cancer, birth defects or other reproductive harm.
- This appliance can cause low-level exposure to some of the substances listed, including benzene, formaldehyde, carbon monoxide, toluene, and soot.

1.4 Manufacturer liability

The manufacturer declines all liability for damage to persons or property caused by:

- Use of the appliance other than as envisaged;
- Not having read the user manual;
- Tampering with any part of the appliance;
- Use of non-original spare parts;
- Not following the safety instructions.

1.5 Identification plate

The identification plate bears the technical data, serial number and brand name of the appliance. Do not remove the identification plate for any reason.

1.6 Disposal



Power voltage

Danger of electrocution

- Turn off the appliance.
- Unplug the appliance from the wall outlet.

- **Old appliances do not belong in household waste!** To comply with current legislation, old appliances, having reached the end of their useful lives, should be taken to a disposal facility where they can be sorted. In this way, any valuable material contained in the old appliances can be recycled and the environment protected. Responsible local authorities or their waste disposal operators can provide further information.

The appliance is packed in non-polluting and recyclable materials.

- Dispose of the packing materials at an appropriate disposal facility.



Plastic packaging

Danger of suffocation

- Do not leave the packaging or any part of it unattended.
- Do not let children play with the plastic bags.



2 Description

2.1 Product description

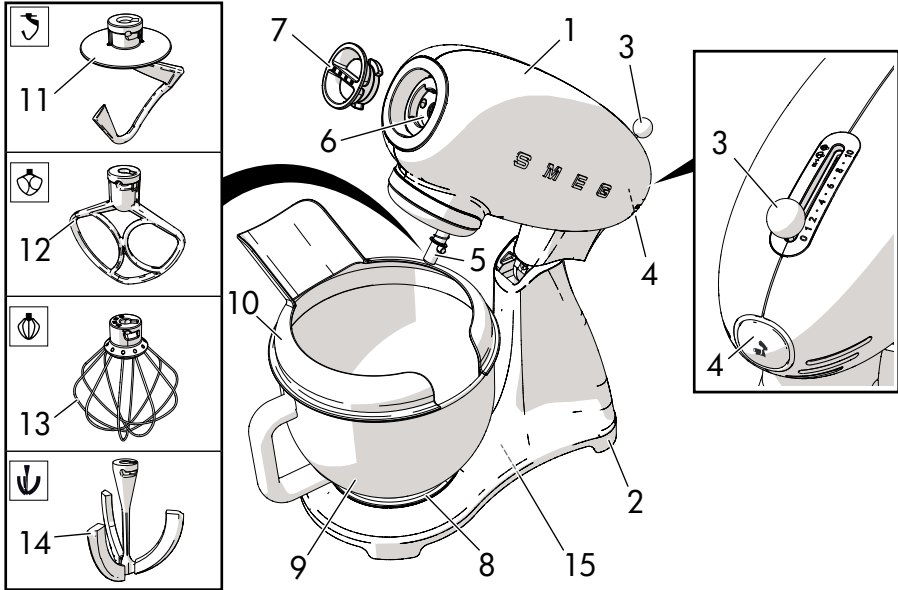

Model SMF02 - SMF03 - SMF13 - Stand Mixer

- | | |
|---|---------------------------------|
| 1 Motor head | 7 Front hub cover |
| 2 Body | 8 Bowl base |
| 3 Power and speed selector | 9 Bowl** |
| 4 Head raising/lowering release button | 10 Splash-proof pouring shield* |
| 5 Lower attachment shaft for supplied attachments | 11 Dough hook |
| 6 Front attachment hub for optional accessories | 12 Flat beater |
| | 13 Wire whisk |
| | 14 Flex edges beater* |

*Standard only on certain models. Only available as an optional accessory.

**The design and materials used for the bowl may vary depending on the mixer.



2.2 Description of parts

Motor head (1)

Upper part of the appliance, rotates the attachments and accessories.

Power and speed selector (3)

Lever for speed selection.

The '0' position of the lever corresponds to the OFF position (appliance off).

To start the appliance, position the lever on one of the 10 available speeds (positions 1-10), depending on the type of mixing required.

See "3.5 Speed setting suggestions" for more details and suggestions.

Head raising/lowering release button (4)

Button which releases the motor head to position it in one of its two possible configurations (raised or lowered position).

Lower attachment shaft for supplied attachments (5)

Attachment shaft for inserting attachments. Holds the attachment solidly in position during planetary movement.

Front attachment hub for optional accessories (6)

Attachment for connecting optional accessories.

It is protected by a removable cover.

Bowl base (8)

Base with clamping plate in which to insert the bowl and which then clamp it into position.

Bowl** (9)

Bowl with a 4.8 liter capacity.

Ideal for holding both large and small quantities of ingredients.

The handle makes it easier to insert and remove.

**The design and materials used for the bowl may vary depending on the mixer.



2.3 Standard accessories

Aluminum dough hook

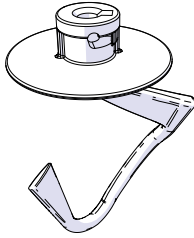

For slowly combining, mixing and kneading leavened dough type mixtures including bread, pasta, pizza, etc.

Aluminum flat beater

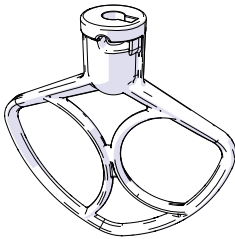

For combining, mixing, and starting all mixing procedures.

For preparing cake batters and pastries, biscuits, icing, etc. and for other, thicker batters and mixes.

Stainless steel wire whisk

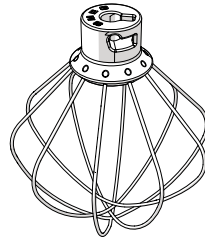

For beating, mixing, whisking and whipping ingredients such as butter, eggs, cream, etc.

Also ideal for preparing creams, custards, sauces, etc.

Flex edges beater*

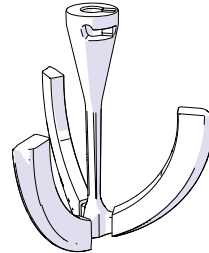

Stainless steel beater with flexible silicone edges.

Useful for mixing doughs and soft batters. Removable edges ensure a uniform consistency throughout the entire process.

* Standard only on certain models. Only available as an optional accessory.



Pouring shield*

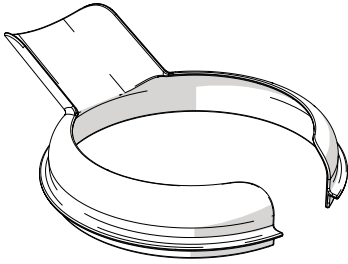

For protecting against splattering and to make it easier to add ingredients while mixing.

Suitable only for use with the stainless steel bowl*.

i The attachments and accessories intended to come into contact with food are made of materials that comply with the provisions of current legislation.

*Standard only on certain models. Only available as an optional accessory.



3 Use



Electrical Shock Hazard

- Plug into a grounded 3-prong outlet.
- Do not remove the ground prong.
- Do not use an adapter.
- Do not use an extension cord.
- Failure to follow these instructions can result in death, fire, or electrical shock.

Volts: 120 Volts AC only.

Hertz: 60 Hz



Your stand mixer has a 3-prong grounded plug. To reduce the risk of electrical shock, this plug will fit into an outlet only one way. If the plug does not fit in the outlet, contact a qualified electrician. Do not modify the plug in any way.

- Do not use an extension cord. If the power supply cord is too short, have a qualified electrician or service technician install an outlet near the appliance.
- A short power supply cord (or detachable power supply cord) should be used to reduce the risk resulting from becoming entangled in or tripping over a longer cord.
- Longer detachable power supply cords or extension cords are available and may be used if care is taken when using them.

If a longer detachable power supply cord or extension cord is used:

- The marked electrical rating of the power supply cord or extension cord should be at least as great as the electrical rating of the appliance.
- The cord should be arranged so that it will not drape over the countertop or tabletop where it can be pulled on by children or tripped over unintentionally.
- If the appliance is of the grounded type, the extension cord should be a grounded type 3-prong cord.

3.1 Before first use

1. Unpack the appliance carefully and remove all packaging materials and any labels and stickers.
2. Clean the body and head of the appliance with a damp cloth.
3. Remove and wash the bowl and accessories (see "3.3 Using the pouring shield").
4. Dry the components thoroughly and place them in their working positions.



3.2 Using the stand mixer

1. Place the mixer on a flat, stable and dry surface.
2. Press the release button (1).
3. Hold down the button and raise the head (2), accompanying its movement with your hand.

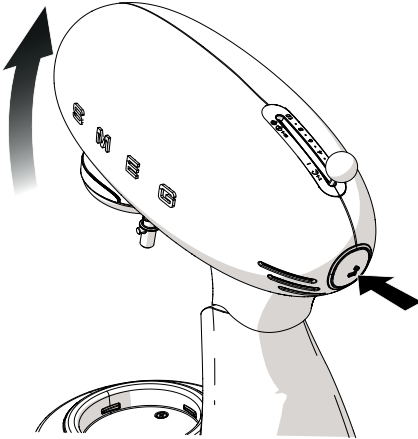

4. Insert the bowl (3) in its base (4).
Grasp the bowl by its handle (5) and turn the bowl (3) clockwise until it locks into place.

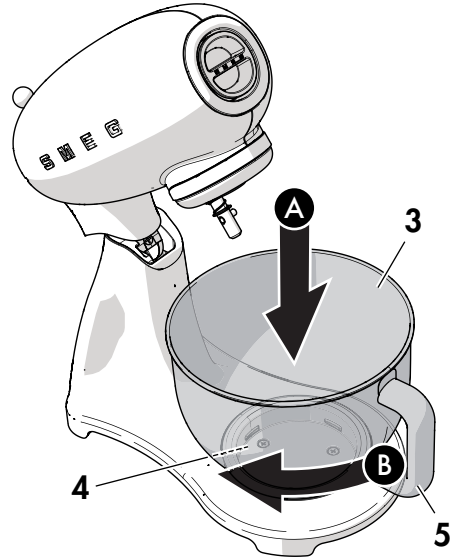

i There may be a slight movement of the motor head while kneading or mixing heavy ingredients or those in large quantities. This is normal and will not compromise the smooth operation and durability of the device.

5. Select the attachment required based on the type of mixing to be performed.



Moving parts

Danger of personal injury

- Do not operate the mixer with the attachment without having locked the bowl in position.



6. Slip the attachment (6) onto the lower attachment shaft (7) and push it upwards. Keep pressing the attachment upwards and turn it counterclockwise until the pin (8) locks fully into place.

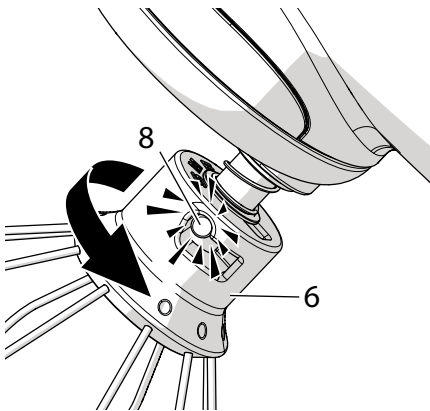
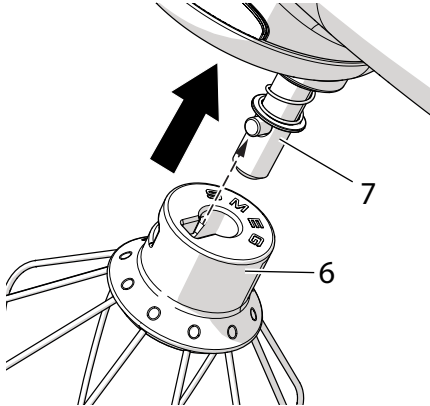

Ensure that the attachment is correctly locked into place on the attachment shaft.

7. Add the ingredients to the bowl.
8. To close, bring the motor head down by pressing the release button (1), and then tilt the motor head (2) backwards slightly until it releases.
9. Keep the button pressed down and lower the head (2), accompanying its movement with your hand.

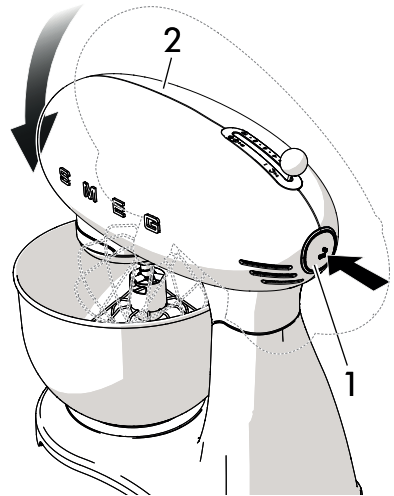

10. Position the pouring shield (9) on the bowl if required, with the chute facing outwards.

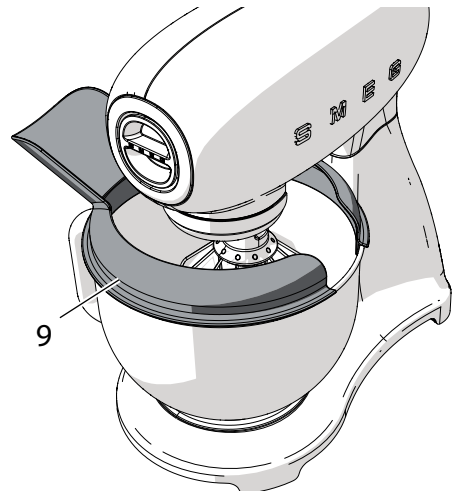



11. Check that the speed selector (**10**) is positioned on '0' (OFF).
12. Insert the plug into the power socket.
13. Select the required speed (from 1 to 10) using the selector (**10**) to start the appliance and begin mixing the ingredients. See "3.5 Speed setting suggestions".

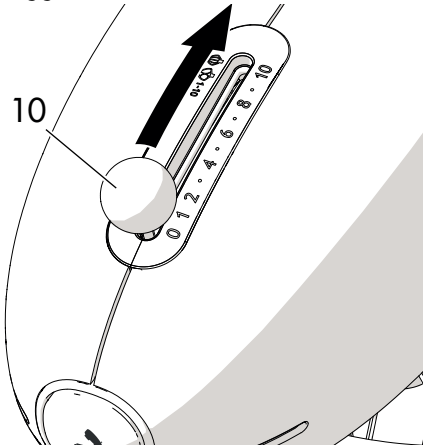

Moving parts

Danger of personal injury and damage to the appliance

- Do not touch the attachments while the appliance is moving
- Do not operate the mixer with the attachment inserted and the bowl empty.



Warning!

- For greater safety, each time that power is cut to the motor, for example by raising the motor head or unplugging the appliance, the speed selector must be returned to zero in order to restart the mixer.



In order to stop the appliance and raise the head to change the attachment or remove the bowl, move the speed selector to '0' (OFF).

**When you have finished using the mixer:**

1. Position the speed selector (10) on '0' (OFF) and unplug the mixer from the socket.
2. Remove the pouring shield, if it is on the bowl (9).

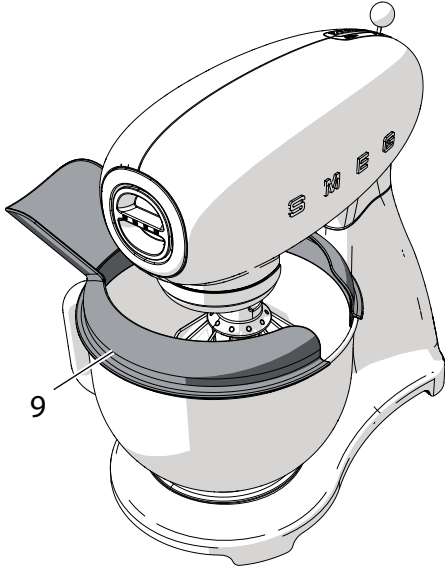

3. Press the release button (1) to raise the head (2).

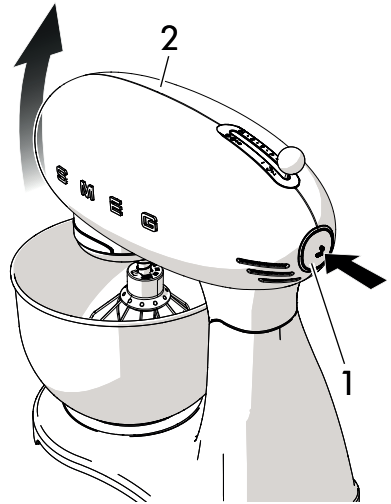



Use

4. Push the attachment (6) upwards slightly and turn it clockwise to unlock it from the pin (8).
Remove the attachment (6) from the lower attachment shaft (7).

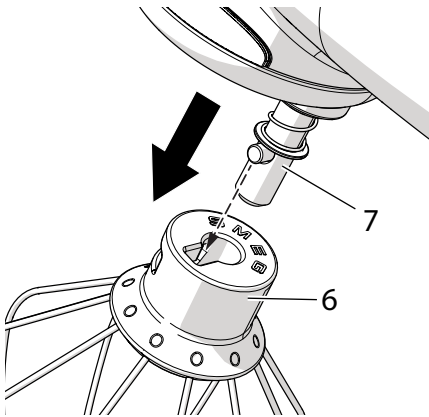
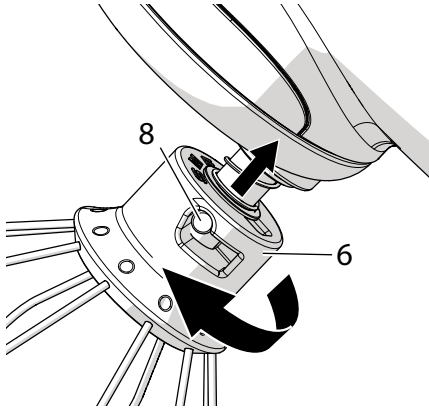

5. Remove the bowl (3) from its base (4) by turning it counterclockwise to release it.

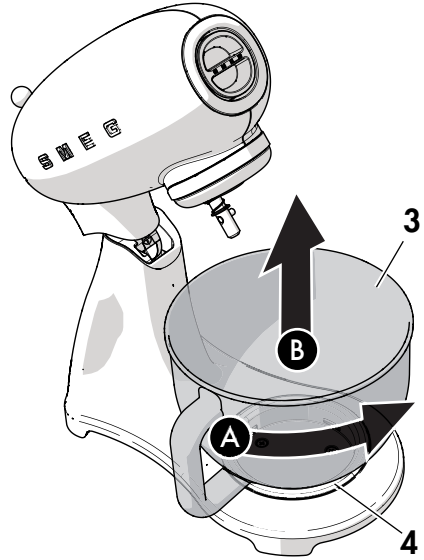



3.3 Using the pouring shield

1. Before placing the splash-proof shield (1) on the upper edge of the stainless steel bowl*, secure the bowl in the base, secure the utensil on the lower attachment and lower the head into the operating position.

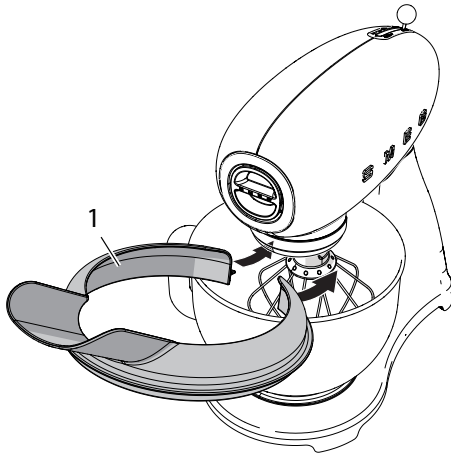

2. Fit the pouring shield with the opening (1) facing outwards in order to add ingredients to the bowl without stopping the mixer.

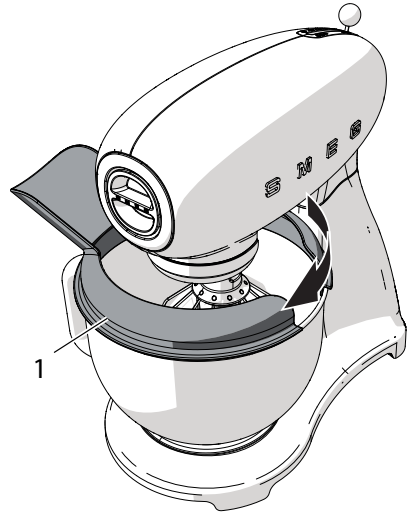

Moving parts

Risk of damage to the pouring shield

- Remove the pouring shield to raise or lower the head with the attachment on the lower attachment shaft.

*Standard only on certain models. Only available as an optional accessory.



3.4 Functions

Safety lock system

The appliance has a safety system which automatically shuts off the appliance when the motor head is raised.

- i** You should nevertheless always place the speed selector in the 0 (OFF) position before pressing the button to move the motor head.

Smooth Start System

When the appliance is started, the speed is gradually increased until the set speed is reached. This prevents damage to the appliance and accessories and ensures that ingredients are not ejected from the bowl.

Planetary movement

Le mouvement des ustensiles du robot pâtissier est de type planétaire.

Le mouvement est généré par la rotation (1) de l'ustensile sur son axe dans le sens opposé au mouvement rotatoire (2) du robot pâtissier. Ceci permet d'atteindre tous les points du bol avec précision, pour un mélange complet et d'excellents résultats pour toute préparation.

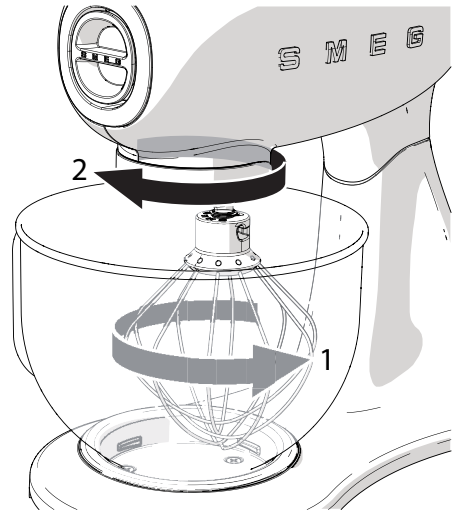

Hot appliance

- Following prolonged use, the upper part of the motor head may become warm. This is not usually indicative of a malfunction, however.



3.5 Speed setting suggestions

- i** The speed selector shows the most appropriate accessory to use with the selected speed.
- The speeds indicated in the table are approximate and can vary depending on the recipe and the interaction of the different ingredients used.

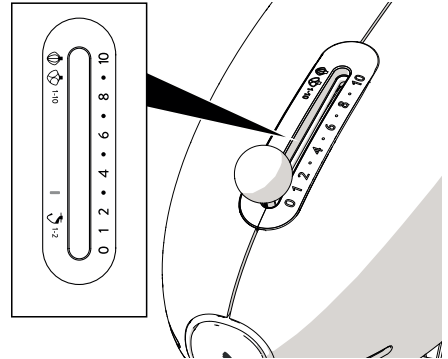

EN







Speed setting	Function	Accessory
LOW 1 - 2	COMBINING AND KNEADING Kneading - preparing leavened doughs (bread, pizza, egg pasta etc.), see "Bread/pizza dough and egg pasta dough".	
LOW 1 - 3	COMBINING Combining ingredients.	
MEDIUM 4 - 7	MIXING Mixing and beating dense batters. Beating eggs and butter, cake mixes such as fruit cake.	
HIGH 8 - 10	WHIPPING AND WHISKING Whisking light or dense batters. whipping cream, egg whites or sauces.	

* Standard only on certain models. Also available as an optional accessory.



Use

Table of recommended accessory, recommended speeds and maximum capacities

Accessory	Preparation	Speed	Time	Min/max capacity
	Egg whites	8 - 10	2-3 min	2-12 ⁽¹⁾
	Cream	8-10	2-3 min	100 ml/1000 ml
 or 	Prepared cake batters	1 - 7	3-4 min	2 kg total batter
	Pastry	1 - 7	3-4 min	2.6 kg total batter
	Bread/pizza dough	1 - 2	4 min	1.8 kg total dough (max 1.2 kg (10 oz) flour)
	Egg pasta dough	1 - 2	5-7 min	500 g total dough with 3 eggs

⁽¹⁾ Average egg size: 53-63 g

i The table should be taken as a guideline only.
The speed and capacity depend on the accessory used, the quantity of mixture in the bowl and the ingredients used.

*Standard only on certain models. Only available as an optional accessory.



General recommendations

- Never exceed the maximum speeds and capacities indicated in the table to avoid damaging the appliance.
- Start the appliance at a low speed until the ingredients are mixed in, then increase the speed according to the operation to be carried out.
- When adding ingredients, always pour them from the edge of the bowl and not directly on the attachment while it is in motion.
- Reduce the speed when you add dry or liquid ingredients to prevent them from splashing out. As soon as the ingredients are well blended, increase the speed.
- Use the pouring shield* for liquid mixtures or when adding powdered ingredients to avoid soiling objects next to the appliance while it is in operation and to prevent splashing.
- Keep the bowl and attachments clean and insert them only when they are perfectly dry.
- Thoroughly clean the body and the head of the appliance with a damp cloth if they become soiled after preparing the recipe.

Tips for whipping egg whites

- For best results, use eggs at room temperature.
- Before beating the egg whites, make sure that the attachment and the bowl are not wet, greasy or soiled with yolk.
- To avoid spills, gradually increase to the suggested speed and beat until the desired consistency is achieved.
- The stand mixer allows you to beat egg whites very quickly. Carefully monitor the process to avoid beating them too much.

Tips for whipping cream

- For best results, use cold whipping cream.
- To avoid spills, gradually increase to the maximum recommended speed and beat until the desired consistency is achieved.
- For whipping a liter (quart) of cream, it is advisable to start at speed **7-8** for the first minute or at least until the cream begins to thicken. Then switch the speed to **10** for the remaining time.

* Standard only on certain models. Only available as an optional accessory.



Tips for working with eggs

- For best results, use eggs at room temperature.
- When preparing dry mixtures, do not use more than 3 medium-sized eggs and add small quantities of water if necessary.

Tips for kneading

- Make sure that the proportion of liquid in the dough is adequate (at least 50-60% by weight with respect to the flour used). Doughs that are too dry can overload the appliance.
- If the appliance works with difficulty, switch it off, divide the dough into two parts and knead the parts separately.

Dough for bread, pizza and egg pasta

- Start the appliance at speed **1** until the ingredients are well combined, then increase to **2**.
- To mix the ingredients better, add the liquid ingredients to the bowl at the beginning of the process.
- **Egg pasta, bread, pizza:** work them only with the **dough hook**.
Use the flat beater only to start the mixing procedure.
NEVER use the flex edges beater*.

Pre-prepared cake batters

- For batters up to 1 kg (2 lb 3 oz): start the appliance at low speed until the ingredients begin to blend, then gradually increase the speed to **7** for the remaining time.
- For batters up to 2 kg (4 lb 7 oz): start the appliance at speed **1** until the ingredients begin to blend, then gradually increase the speed to **3-4** for the remaining time.

Batters for desserts

- We recommend using cold ingredients to prepare shortcrust and the like, unless the recipe suggests otherwise.
- For preparing cakes, first beat the butter and the sugar together at room temperature, then add the eggs, and finally the flour.

• There may be a slight movement of the motor head while kneading or mixing heavy ingredients or those in large quantities. This is normal and will not compromise the smooth operation and durability of the device.

*Standard only on certain models. Only available as an optional accessory.

4 Cleaning and Care

4.1 Instructions



Improper use Danger of electrocution

- Switch off and unplug the appliance before cleaning the mixer and its attachments and accessories.



Improper use Risk of damage to surfaces

- Do not use steam jets to clean the appliance.
- Do not use cleaning products containing chlorine, ammonia or bleach on steel parts or parts with metallic finishes (e.g. anodized, nickel- or chrome-plated).
- Do not use abrasive or corrosive detergents (e.g. powder products, stain removers and metallic sponges).
- Do not use rough or abrasive materials or sharp metal scrapers.

4.2 Maintenance

All service should be performed by an authorized service representative.

4.3 Ordinary daily cleaning

This manual contains instructions for cleaning, maintenance and recommendations from the manufacturer to the customer. Any other interventions should be carried out by an authorised service centre.

Before cleaning, ALWAYS remove the plug from the mains and allow the appliance to cool down. Never immerse the motor base (2) in water or other liquids.



Splattered liquids or batters should be removed immediately using a soft, damp, cotton cloth.

The dough hook, flat beater, flex edge beater* and the stainless steel bowl* can be washed in a dishwasher.

The wire whisk and the pouring shield* can be washed by hand using a neutral detergent and a soft sponge.

The silicone edges of the flex edge beater* can be removed and washed in a dishwasher.

The glass bowl* can be washed by hand with warm water and a neutral detergent or in a dishwasher using a low temperature (maximum 50° C) program.

The ring nut at the base of the bowl can be removed and washed separately by hand using a neutral detergent and a soft sponge.

*Standard only on certain models. Only available as an optional accessory.



Cleaning and care

4.4 What to do if...

Problem	Possible cause	Solution
The motor will not start	The motor has overheated.	Disconnect the mixer from the power and leave the motor to cool.
	The plug is not properly inserted in the power socket.	Insert the plug into the power socket. Do not use adaptors or extensions. Check that the breaker is on.
	The cable is defective.	Have the cable replaced at an Authorized Service Center.
	Lack of power.	Check that the house main breaker is on.
	The head has been raised during operation.	The safety lock system has operated. Move the speed selector to 0 (OFF), press and hold down the button on the rear to release the head and lower it.



Problem	Possible cause	Solution
<p>The mixer vibrates</p>	<p>The mixer is not resting on a stable surface.</p>	<p>Place the mixer on a flat, stable surface.</p>
	<p>The anti-slip rubber feet are worn.</p>	<p>Have them replaced at an Authorized Service Center.</p>
	<p>The speed used is too high or the load is excessive.</p>	<p>Set a lower speed and ensure the bowl has not been overfilled.</p>
	<p>The bowl has not been correctly locked into its base.</p>	<p>Check that the bowl is correctly locked into its base.</p>
<p>The attachments hit the walls of the bowl</p>	<p>The lower attachment shaft has come loose over time.</p>	<p>Have the mixer checked and adjusted at an Authorized Service Center.</p>
	<p>The attachment or the bowl is not properly inserted.</p>	<p>Turn the speed selector to 0, press the button on the back to lift the head to check that the attachment is inserted correctly in the lower attachment shaft and that the bowl is inserted correctly in the base.</p>



Cleaning and care

Problem	Possible cause	Solution
The attachment is struggling to turn inside the bowl	The dough mixture is too thick and is stopping the attachment from turning.	Add water or other liquid to loosen the dough mixture.
	The bowl is too full.	Remove half the bowl's contents and work it separately.



If the problem has not been resolved or in the event of another type of fault, contact your local technical support center.

