



1	Instructions	2
1.1	General safety instructions	2
1.2	Identification plate	4
1.3	Manufacturer liability	4
1.4	Appliance purpose	5
1.5	Disposal	5
1.6	This user manual	6
1.7	How to read the user manual	6
2	Description	7
2.1	General Description	7
2.2	Control panel	8
2.3	Controls description	8
2.4	Side panel	9
2.5	Available accessories	9
2.6	Other parts	10
3	Use	11
3.1	First use	11
3.2	First time switching on	11
3.3	Home screen	12
3.4	Cooking parameters and default values	13
3.5	Cooking modes	13
3.6	Step cooking	13
3.7	Cooking with a recipe	19
3.8	Special functions	21
3.9	Cooking advice	23
4	Cleaning and maintenance	26
4.1	Cleaning the appliance	26
4.2	Cleaning the door	26
4.3	Cleaning the oven cavity	28
4.4	Extraordinary maintenance	30
4.5	If the appliance is not working properly	33
5	Installation	34
5.1	Electrical connection	34
5.2	Water connection	36
5.3	Positioning	38

TRANSLATION OF THE ORIGINAL INSTRUCTIONS

We advise you to read this manual carefully, as it contains all the instructions for maintaining the appliance's aesthetic and functional qualities. For further information on the product: www.smegfoodservice.com



Instructions

1 Instructions

1.1 General safety instructions

Risk of personal injury

- During use the appliance and its accessible parts become very hot.
- Never touch the heating elements during use.
- Keep children under the age of eight at a safe distance unless they are constantly supervised.
- Children must never play with the appliance.
- Never try to put out a fire or flames with water: Turn off the appliance and smother the flames with a fire blanket or other appropriate cover.
- Keep the oven door closed during cooking.
- Protect your hands by wearing oven gloves when moving food inside the oven.
- Do not touch the heating elements inside the oven.
- Do not pour water directly onto very hot trays.
- Do not allow children to approach the appliance when it is in operation.
- If you need to move food or at the end of cooking, open the door 5 cm for a few seconds, let the steam come out, then open it fully.
- **WARNING:** opening the door during or after cooking can let out hot steam.
- Cleaning and maintenance must not be carried out by unsupervised children.
- Do not spray any spray products near the appliance.
- Do not use or leave flammable materials near the appliance.
- Do not use plastic cookware or containers when cooking food.
- Do not put sealed tins or containers in the oven.
- Do not leave the appliance unattended during cooking operations where fats or oils could be released.
- Remove all trays and racks which are not required during cooking.
- Do not insert pointed metal objects (cutlery or utensils) into the slots in the appliance.
- Switch off the appliance immediately after use.
- Do not modify this appliance.
- Have qualified personnel carry out installation and assistance interventions according to the standards in force.
- Do not try to repair the appliance yourself or without the intervention of a qualified technician.



- If the power supply cable is damaged, it must be replaced by the manufacturer, by Technical Support or other qualified personnel in order to ensure a hazard is not created.
- Do not place containers with liquids or food products which can melt during cooking on the upper shelves which are not visible.
- Do not touch the metal tip of the temperature probe after cooking.
- The floor next to the appliance could be very slippery. Be very careful.
- The terminal indicated by the  symbol links up parts that are normally earthed. Connect the appliances appropriately using this terminal in order to make sure that they are equipotential.
- Have the electrical connection performed by authorised technical personnel.
- The appliance must be connected to ground in compliance with electrical system safety standards.
- Disconnect the mains power supply.
- Do not pull the cable to remove the plug.
- Use H07RN-F cables that can withstand a temperature of at least 75°C.
- The tightening torque of the screws of the terminal supply wires must be 1.5- 2 Nm.

Risk of damaging the appliance

- Racks and trays have to be inserted into the side guides until they come to a complete stop. The mechanical safety locks that prevent the rack from being taken out accidentally must face downwards and towards the back of the appliance.
- Do not seat on the appliance.
- Do not use abrasive or corrosive detergents (e.g. scouring powders, stain removers and metallic sponges) on glass parts.
- Do not use steam jets to clean the appliance.
- Do not obstruct ventilation openings and heat dispersal slots.
- Never leave the appliance unattended during cooking operations where fats or oils could be released.
- Never leave objects on the cooking surface.
- Do not use the appliance to heat rooms for any reason.
- Remove any food residues or large spills from previous cooking operations from the inside of the oven.
- Do not cover the bottom of the oven cavity with aluminium or tin foil sheets.
- If you wish to use greaseproof paper, place it so that it will not interfere with the hot air circulation inside the oven.



Instructions

- Do not place pans or trays directly on the bottom of the oven cavity.
- Do not pour water directly onto very hot trays.
- Do not leave the temperature probe in the oven cavity when it is not in use.
- Do not use cleaning products containing chlorine, ammonia or bleach on parts made of steel or that have metallic surface finishes (e.g. anodizing, nickel- or chromium-plating).
- Do not use abrasive or corrosive detergents (e.g. scouring powders, stain removers and metallic sponges) on glass parts.
- Do not use rough or abrasive materials or sharp metal scrapers.
- Shut off the power supply during cleaning and maintenance procedures.
- A fixed electrical connection must incorporate a means of electrical isolation per electrical wiring code.

For this appliance

- Do not rest any weight or sit on the open door of the appliance.
- Take care that no objects are stuck in the doors.
- Have the condition of the components checked regularly by Technical Support.
- The A-weighted sound pressure level is below 70 dB (A).

1.2 Identification plate

The identification plate bears the technical data, serial number and brand name of the appliance. Do not remove the identification plate for any reason.

1.3 Manufacturer liability

The manufacturer declines all liability for damage to persons or property caused by:

- Use of the appliance other than that specified
- Failure to comply with the instructions in the user manual
- Tampering with any part of the appliance
- Use of non-original spare parts.



1.4 Appliance purpose

This appliance is intended for cooking food in the professional catering environment. Every other use is considered improper.

This appliance must not be used by people (including children) of reduced physical or mental capacity, or lacking in experience in the use of electrical appliances, unless they are supervised or instructed by adults who are responsible for their safety.

1.5 Disposal



This appliance conforms to the WEE directive (2012/19/EU) and must be disposed of separately from other waste at the end of its service life. The appliance does not contain substances in quantities sufficient to be considered hazardous to health and the environment, in accordance with current European directives.

To dispose of the appliance:

- Cut the power supply cable and remove it along with the plug.



Power voltage
Danger of electrocution

- Disconnect the mains power supply.
- Unplug the appliance.

- Deliver the appliance to the appropriate recycling centre for electrical and electronic equipment waste, or return it to the retailer when purchasing an equivalent product, on a one for one basis.

Our appliances are packaged in non-polluting and recyclable materials.

- Deliver the packing materials to the appropriate recycling centre.



Plastic packaging
Danger of suffocation

- Do not leave the packaging or any part of it unattended.
- Do not let children play with the plastic bags.



Instructions

1.6 This user manual

This user manual is an integral part of the appliance and must therefore be kept in its entirety and within the user's reach for the whole working life of the appliance.

Read this user manual carefully before using the appliance.

1.7 How to read the user manual

This user manual uses the following reading conventions:

Instructions



General information on this user manual, on safety and final disposal.

Description



Description of the appliance and its accessories.

Use



Information on the use of the appliance and its accessories, cooking advice.

Cleaning and maintenance



Information for proper cleaning and maintenance of the appliance.

Installation



Information for the qualified technician: Installation, operation and inspection.



Safety instructions



Information



Advice

1. Sequence of instructions for use.

- Standalone instruction.



2 Description

2.1 General Description

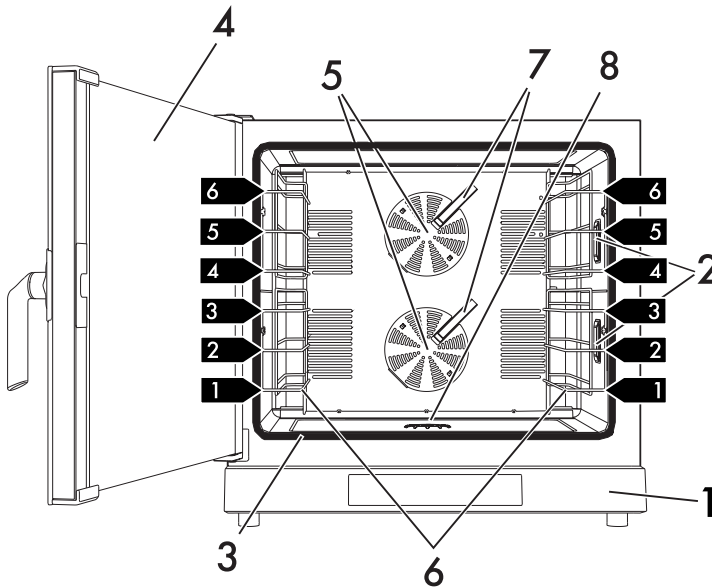

- 1) Control panel
- 2) Oven lights
- 3) Seal
- 4) Door
- 5) Fans

- 6) Tray support frames
- 7) Water intake line
- 8) Washing water drain (on some models only)
- 1,2,3** Frame shelf



Description

2.2 Control panel

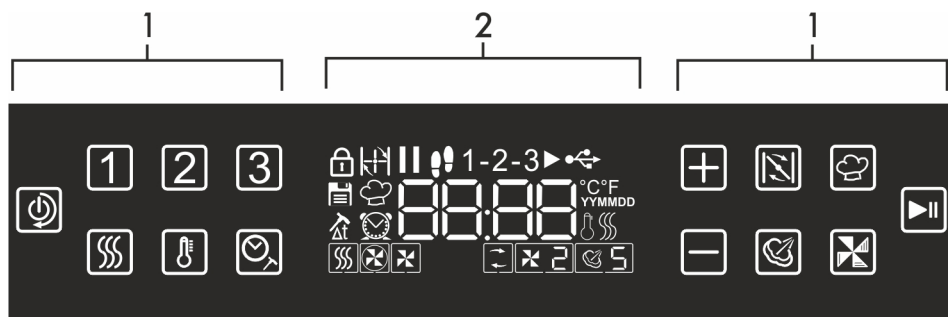

1 Backlit capacitive buttons

2 LCD display and icons

2.3 Controls description

Backlit capacitive buttons

- | | | | |
|--|----------------------------------|--|-----------------------|
| | On-Off/Back/Stand-by | | Increase |
| | Step 1 | | Open/close exhaust |
| | Step 2 | | Cooking with a recipe |
| | Step 3 | | Decrease |
| | Preheating setting | | Humidification |
| | Temperature setting | | Fan adjustment |
| | Time settings/core probe cooking | | Start/pause |



LCD display and icons



Alphanumeric display



Cooking steps



Ventilation level



Level of humidification



Cooking in progress



Pause cooking



Recipes lock



Saved recipe



Core probe with Δt



Cooking duration



Delayed start



Open/close exhaust



Select recipes



Cooking temperature



Preheating temperature



Degrees Celsius/Fahrenheit

icons



USB connection icon



Set date icon

2.4 Side panel

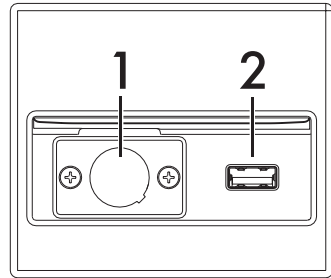

The side panel is located close to the bottom left corner on the right hand side of the appliance.



1 Core probe socket (on some models only).



2 USB port.

2.5 Available accessories

Core probe (optional, on some models only)

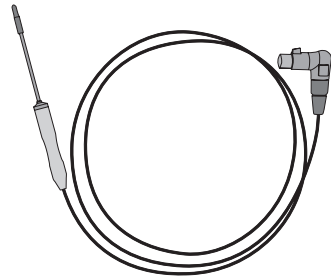

Using the core probe, it is possible to cook according to the temperature measured at the centre of the food.



Description

2.6 Other parts

Shelves

The appliance features shelves to position trays and racks at different heights. The insertion heights are indicated from the bottom upwards (see “General Description”).

Internal ventilation

The internal fans (together with the heating elements) are switched on and off according to the cooking mode selected. Depending on the model, the speed of the fans can also be adjusted during cooking.

Retractable spray head (on some models only)

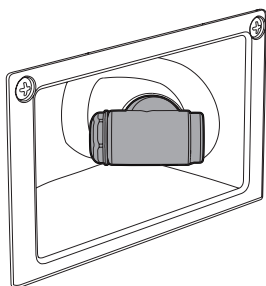

To make cleaning easier, the appliance is fitted with a water spray head located in a special compartment on the right hand side.

Washing water drain (on some models only)

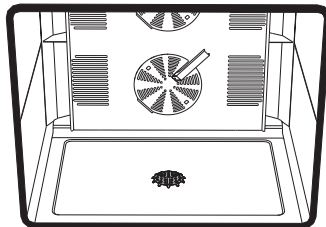

The appliance is fitted with a system for draining the washing water. It is located in the centre of the bottom of the oven and protected by a perforated grille.

Safety thermostat

The appliance is equipped with a safety device that triggers in case of serious malfunction.

Only for the installer/technical support:

- 1) Unscrew the protective cover for the thermostat with the dedicated tool.
- 2) To reset the safety thermostat, press the button on the back.

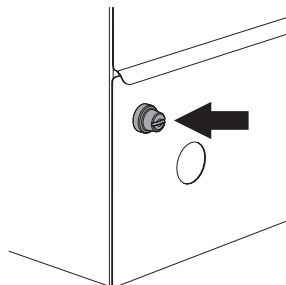

Contact Technical Support immediately after the safety device has triggered to check if there are any faults.



3 Use

3.1 First use

- 1) Remove any protective film from the outside or inside of the appliance, including accessories.
- 2) Remove any labels (apart from the technical data plate) from the accessories and from the oven cavity.
- 3) Remove and wash all the appliance accessories (if fitted) (see "Cleaning and maintenance").
- 4) Heat the empty oven at the maximum temperature to burn off any residues left by the manufacturing process.

3.2 First time switching on





 The oven is designed for a maximum load of 18 kg.

When the appliance is connected to the mains power socket, all the LEDs and the buttons on the display light up for approximately 3 seconds.

When finished, only the  button (stand-by screen) appears on the display.

Setting the date and time





During this procedure, you have to press the  button to confirm each step, or the  button to return to the previous step (apart from the first one). Use the  /  buttons to edit the parameters for each step.

First you have to enter the year.



The following will be shown next to the numeric display "YY", "MM" and "DD" for year, month and day respectively.

The numeric display shows .

Then  is shown for the month and  for the day.

Now set the current time (hours and minutes- format 0-24h). The

numeric display shows .







Setting the appliance ID



- The appliance ID is a unique 2-digit code (from 01 to 99) that identifies the appliance (see “Upload and download functions”).
- This setting is enabled only when the appliance is switched on for the first time or after a factory reset.

After having set the date and time, you are prompted to set the appliance ID:

The numeric display shows:  and it is possible to change it through  /  buttons. Once the date, time and appliance ID have been set, you can use the  button to go to the home screen.

3.3 Home screen



- All the buttons on this screen are active and the current time is displayed.
- From this screen, press  for at least 2 seconds to go to the stand-by screen.

From this screen, you can:

- create a step cooking cycle
- select a cooking recipe that has been saved
- reset the date and time
- perform a factory reset
- set a delayed start cooking function
- set the exhaust opening / closing
- activate the cooling function
- enable the recipes lock
- download/upload recipes and download HACCP data.



3.4 Cooking parameters and default values

Parameter	Default value
Cooking temperature	Not set ("---°C")
Cooking duration	Not set (---°C)
Cooking function	Fan with circulaire
Ventilation	Level 2 (max) with reverse fans
Humidification	Level 0 (disabled/manual)
Preheating	Disabled
Exhaust	Open



Fan with circulaire (activated by default)

The combination of the fan and the circulaire heating element (incorporated in the rear of the oven) allows you to cook different foods on several levels, as long as they require the same temperatures and same type of cooking. Hot air circulation ensures instant and even distribution of heat. It will be possible, for example, to cook fish, vegetables and biscuits simultaneously (on different levels) without mixing odours and flavours.

3.5 Cooking modes

The appliance has two cooking modes:

1. Step cooking (buttons);
2. Cooking with a recipe (button).

3.6 Step cooking



Step cooking is a cooking method that is carried out in consecutive stages (maximum 3) in which different cooking parameters can be set for each stage.

From the home screen, press the button (it becomes red). It is now possible to set the cooking parameters.

Cooking temperature



You have to set a temperature, otherwise the step will not be enabled and it will not be possible to start cooking. You can select between °C and °F by pressing and holding the button during set-up.

To set the cooking temperature:



- Press the button (it becomes red).
- The numeric display shows "---"
- next to the °C (or °F) icons;
- Icons and appear with the default function and ventilation level.





Use



If the selected temperature is at least 90°C (194°F), the  icon will also appear.

The  /  buttons are used to select the temperature (keep pressed to fast forward).

- Minimum temperature 30°C (86°F).
- Maximum temperature 270°C (518°F).

Once the temperature has been set, the  icon appears and you can start cooking by pressing the  button. In this case, the cooking program will have only one step and default values will be used for all the other parameters.



Cooking duration

To set the cooking duration:



If you do not set a cooking duration, by confirming the initial values "--:--", cooking will continue indefinitely and will have to be stopped manually.

1. Press the  button (it becomes red) and the icon appears .

Use the  /  buttons to set a cooking duration.

- Minimum duration "--:--" (manual stop).
- Maximum cooking: 99 hours.

Preheating



The oven is always preheated before the first cooking step.

To set up the preheating:



1. Press the  button (it becomes red) and the  icon appears.
2. Use the  /  buttons to select the preheating temperature.



The oven is preheated using the fan with circulaire function and with the maximum fan speed.

Fan speed

To adjust the fan speed:

1. Press the  button (it becomes red):
2. Use the  /  buttons to select the ventilation level



Level 1 - low speed, circulaire heating element at minimum power



Level 1 - low speed, circulaire heating element at minimum power with fan reversal.



Level 2 - high speed, circulaire heating element at maximum power with fan reversal.



Humidification



Humidification can only be activated if:

- The fan speed is set to level 2 (maximum).
- The cooking temperature is at least 90°C (194°F).

To set the level of humidification:

1. Press the button (it becomes red)
2. Use the / buttons to select the level of humidification (from level 0 to level 5).



The humidification levels represent the frequency at which regular cycles of 2 seconds are activated in which water is introduced to the oven cavity followed by 15 seconds in which no water is introduced.

Level of humidification	Activation frequency
0	Disabled / manual
1	1 cycle every 8 minutes
2	1 cycle every 6 minutes
3	1 cycle every 4 minutes
4	1 cycle every 2 minutes
5	1 cycle every 35 seconds

If you select level 0, humidification can be activated manually by pressing the button (only with a temperature of at least 90°C-194°F). In this case, humidity will be provided for 2 seconds followed by a 15-second pause (during which the corresponding icon disappears to indicate that humidification has been disabled until the end of the cycle).

Adding 1 cooking step



A second or third cooking step can be added only if a temperature and cooking duration have been set for the previous step.

After having set the parameters for the first step:

1. Press the button (it becomes red)
2. Set the cooking parameters as per step 1. Once the temperature has been set, the icon appears

Once the parameters for step 2 have been set, you can start cooking by pressing the button, or you can add the last cooking step using the button, setting the parameters as described above (in this case, the icon will appear once the temperature has been set).



Each additional step will initially be given the default cooking parameters (see "Cooking parameters and default values").

Removing one or more cooking steps

To remove a cooking step, press and hold the button of the step that you wish to remove. When you remove a step, it also deletes any subsequent steps (if set).

For example, if there are 3 active steps:

- Pressing and holding the button will remove only step 3.
- Pressing and holding button will remove step 2 and 3.



Use

- Pressing and holding the button will remove all steps and take you back to the parameter setting screen for the first step showing the default values.

Starting cooking

With preheating

- Once the cooking cycle has been set, press (it becomes red) to start.
 - The lights remain off and the icon appears on the display.
 - The flashing icon appears.
 - The increasing internal temperature is displayed.
 - The target preheating temperature can be displayed using the button and it can be modified using the and buttons.
 - You can start cooking immediately by pressing and holding the button.

Once preheating has ended, the appliance goes into pause mode:

- a series of beeps are emitted and the light comes on;
- the icon appears and the icon becomes steady.
- the icon becomes white again and flashes.

2. Open the door.

3. Place the food in the oven.

Cooking starts when the door is closed.



If the food was placed in the oven from the beginning, simply press the button to start cooking.

Without preheating

- Once the cooking cycle has been set, press (it becomes red). Cooking starts, the light comes on and the icon appears.

Cooking with the core probe

The core probe is a thermometer that measures the temperature directly at the centre of the food and stops the cooking cycle when it detects that the temperature is the same as the one set by the user.

- Remove the protective rubber cap from the tip of the probe before using it for the first time.
- Connect the core probe to the appropriate socket on the right hand side of the appliance.



Note: press the release button to remove the core probe

- The icon appears when the probe is connected.
- Pressing causes the temperature display to appear.
- Use the / buttons to set the target temperature (from 30°C to 90°C).
- Set the other parameters as explained above and start cooking or save as a recipe.



Cooking will end when the food reaches the set target temperature for the core probe.



When cooking / preheating is in progress, press  for at least 3 seconds to display the actual temperature of the probe (displayed for 5 seconds).



If you start a recipe that uses a core probe, but with the probe disconnected  appears on the alphanumeric display. Cooking will resume automatically as soon as it is connected.









If the probe is removed during cooking, it will stop automatically and will have to be set up again.

Cooking with the core probe Δt





In this mode, a constant temperature difference (Δt) is maintained between the temperature inside the appliance and the target temperature of the probe during cooking.

1. The  icon appears when the probe is connected.
2. Pressing  causes the temperature display to appear.
3. Press  again,  appears on the display.
4. Use the  /  buttons to set the temperature difference Δt (from 5°C to 100°C).
5. Set the other parameters as explained above and start cooking or save as a recipe.

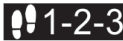
Cooking in progress

During cooking, the flashing  1-2-3 icon will indicate the number of the cooking step carried out.

- The step icon only displays the number of the steps set.
- The numeric display shows the sum of the times of the individual steps.
- The icons of the relative parameters are displayed for each step.
- At the end of a step, the appliance passes directly to the next step.
- When the remaining time is less than one minute, the numeric display shows a countdown of the seconds remaining.

If the cooking program in progress is a recipe, pressing the  button displays the number associated with it; press the  button or wait 5 seconds to go back to the cooking cycle in progress screen.







Use

- If the last step doesn't include a cooking time ("--:--" on the display), the numeric display counts the time starting from "00:00" and cooking has to be stopped manually.



The parameters can be modified during cooking. After each modification, press

 or wait for 10 seconds to exit from modification mode.

- Display and if necessary modify the set temperature (for the step in progress) by briefly pressing the  button.
- Display the current oven temperature by pressing and holding the  button.
- Modify the cooking time of the step in progress by pressing the  button and the  and  buttons (it is not possible to set the time to "--:--").
- Modify the fan speed and the level of humidification using the relative buttons (if provided).



Pausing, restarting and stopping a cooking cycle

To pause cooking:

- The  button switches off the fan and the heating elements, but the countdown continues. To resume cooking, press the  button again.
- Open the door to pause the countdown and the heating elements. Close the door to resume cooking.

The  icon anyway appears on the display.

To stop cooking:

1. Pause the cooking cycle that is in progress using the  button.
2. When the  button is pressed, cooking is stopped and you are taken back to the parameter and cooking step setting screen.

It is now possible to modify the cooking parameters, add or remove steps and save the cooking cycle as a recipe.





When cooking is paused or in progress, the parameters of the step in progress can be modified using the corresponding buttons (they become red).



At the end of the cooking cycle

- A series of beeps are emitted and the light comes on.

i When cooking has ended, opening and closing the door switches off the light.

- The icon appears 
- "00:00" flashes on the time display.
- Pressing the  button will take you back to the cooking parameter setting screen where you can modify the parameters and steps, or save the cooking cycle as a recipe.
- If the cooking cycle that has just ended was a recipe, opening the door or pressing the  button takes you directly to the recipe management screen on which the recipe that has just finished is displayed.

3.7 Cooking with a recipe

i A recipe is an automatic cooking program that was previously saved or downloaded via the USB port.

This mode allows you to recall an automatic program (Recipe) that consists of one or more cooking stages.

The recipes can be created in two ways:

- 1 Set up a cooking cycle and save it as a recipe.
- 2 Download recipes from a USB device to the appliance's memory (See "Special functions").



Creating a new recipe

1. Set up a step cooking cycle (See "Step cooking").

2. Press and hold the  button (it becomes red); you are taken to the recipe management screen.

- The numeric display shows the number associated with the position of the recipe in the memory and the  icon appears.

i You can save up to a maximum of 99 recipes.

- The  icon appears only when the selected position in the memory is already used by another recipe.
- Briefly pressing the  button takes you back to the previous screen (the set cooking cycle is maintained but not saved).
- Pressing and holding the  button takes you to the stand-by screen (the set cooking cycle is discarded and not saved).

3. Use the  and  buttons to select a position in the memory.

4. Press and hold the  button again to save the previously set cooking cycle as a recipe. A beep is issued to confirm.

5. After it has been saved, you are taken back to the previous screen.









Use



If the recipes lock is enabled, when you try to save the recipe, the  icon appears briefly and the system prevents you from saving it (See "Special functions").





Calling up a previously saved recipe

From the home screen:

1. Press the  button; you are taken back to the recipe management screen.
2. Use the  and  buttons to select a recipe.
- Press the  button to start the recipe.
- Press the  button to go back to the home screen.
- Press and hold the  button to go the stand-by screen.





Changing an existing recipe:

After having selected a recipe (See "Calling up a previously saved recipe").

1. Press and hold the  button to show the selected recipe; you are taken to the cooking parameter setting screen.
2. Modify the parameters and steps using the relative buttons.
3. After having made the changes, press and hold the  button again to save the recipe in the same position or a different position in the memory (select the position using the  and  buttons).

Deleting a recipe

From the home screen:



1. Press the  button to move to the recipe management screen.
2. Use the  and  buttons to select the recipe you wish to delete.
3. Press and hold both the  and  buttons to access the delete mode.



This mode also allows you to select the recipes to be deleted using the relative buttons



If the recipe lock is enabled, it will prevent the user from accessing the delete mode (the  icon appears briefly, see "Special functions").

- The number associated with the recipe starts to flash on the numeric display.
 - Press  to exit from delete mode.
4. Press the  button to confirm deletion; a beep is emitted and you are taken to the recipe management screen.
 5. Press  to go back to the home screen.



3.8 Special functions

Recipes lock

Function that prevents recipes from being saved or deleted.



From the home screen, the icon indicates that the recipes lock is enabled

From the home screen:

1. Press and buttons for at least 8 seconds to disable it.

Delayed start

This function allows you to start cooking at a set time.

From the home screen:

Press .

The numeric display shows "00:00".

2. Use the and buttons to set the required time.
3. Press to confirm.
4. After confirming, you will be taken back to the home screen and the icon will be displayed to the left of the numeric display.

If you wish, you can now set-up a new cooking cycle or call up a recipe; it will start at the time that was previously set.



- A delayed start can only be set from the home screen.
- If cooking does not start, the delayed start time will be considered to be for the following day.

To cancel a delayed start, simply press and hold on the home screen until the stand-by screen appears.

Cooling

This function allows the oven cavity to be cooled if the internal temperature is higher than 60°C (140°F).

From the home screen, press and hold the button (it becomes red).

- The fan is activated at high speed.
- The numeric display shows the decreasing internal temperature.
- The flashing icon appears.

To deactivate the function:

1. Wait until the temperature has reached 60°C.
2. Press the or button to go back to the home screen.
3. Press and hold the button to go to the stand-by screen.



This function cannot be activated if the internal temperature is less than 60°C.





Use

Factory reset

This function allows you to:

- Reset the system date and time
- Reset the appliance ID
- Delete saved recipes
- Reset the units of measure for temperature to °C
- Disable the recipe lock.

From the home screen:

1. Press the  and  buttons at the same time for at least 8 seconds.
2. If the command has been accepted, all the buttons will flash red for a few seconds and you are taken to the stand-by screen, without the time indication.



After a factory reset, the time and date have to be re-entered (see “Switching on for the first time”).

Upload and download functions









These functions can only be used from the main screen.

Recipes can be uploaded and downloaded and HACCP data downloaded using a USB device.





HACCP data is a log of all the appliance's operations in the form of a file that can be downloaded and viewed by qualified personnel.



To enable these functions, use one of the following key combinations, each of which is associated with a specific function:

- Press the  and  buttons at the same time for 8 seconds to upload recipes from the USB device.
- Press the  and  buttons at the same time for 8 seconds to download recipes to the USB device.
- Press the  and  buttons at the same time for 8 seconds to download HACCP data to the USB device.



1. Insert the USB key (the  icon flashes).

i If the USB key has not been inserted, the  icon continues to flash until it is inserted.

2. Once a function has been enabled, press  to confirm (the button becomes red and the  icon becomes steady). To cancel the operation, press the  button.

3. Once completed, the  button becomes white again and after a few seconds, you are taken back to the home screen.

i The appliance ID is useful for example when downloading recipe files or HACCP data from multiple ovens onto a USB device; there is no risk of the files being overwritten as they are indicated with the same ID.

3.9 Cooking advice

General advice

- Use a fan assisted function to achieve consistent cooking at several levels.
- It is not possible to shorten cooking times by increasing the temperature (the food could be overcooked on the outside and undercooked on the inside).

Advice for cooking meat

- Cooking times vary according to the thickness and quality of the food and to consumer taste.
- Use a meat thermometer when roasting meat, or simply press on the roast with a spoon. If it is hard, it is ready; if not, it needs another few minutes cooking.

Advice for cooking desserts/pastries and biscuits

- Use dark metal moulds: They help to absorb the heat better.
- The temperature and the cooking time depend on the quality and consistency of the dough.
- To check whether the dessert is cooked right through: At the end of the cooking time, put a toothpick into the highest point of the dessert. If the dough does not stick to the toothpick, the dessert is cooked.
- If the dessert collapses when it comes out of the oven, on the next occasion reduce the set temperature by about 10°C, selecting a longer cooking time if necessary.



Use

Advice for defrosting

- Place frozen foods without their packaging in a lidless container on the first shelf of the oven.
- Avoid overlapping the food.
- To defrost meat, use the rack placed on the second level and a tray on the first level. In this way, the liquid from the defrosting food drains away from the food.

To save energy

- Stop cooking a few minutes before the time normally used. Cooking will continue for the remaining minutes with the heat which has accumulated inside the oven.
- Reduce any opening of the door to a minimum to avoid heat dispersal.
- Keep the inside of the appliance clean at all times.

Slow cooking with the probe

- This type of cooking is recommended for tender and lean meats whose core temperature should not exceed 65°C. Set the temperature of the oven to between 90° and 100°C. This increases the cooking time, but maintains the quality of the food and prevents an excessive reduction in its volume.
- For a better result, brown the meat in a pan over high heat for 1 or 2 minutes on each side before slow cooking.

How to insert the probe correctly

- 1) Place the food on a tray.
- 2) Insert the tip of the probe into the food before placing it in the oven.

For best results, make sure that the temperature probe is placed transversely in the thickest part of the food and for least 3/4 of its length. Make sure that it does not touch the tray underneath and that it does not protrude from the food.

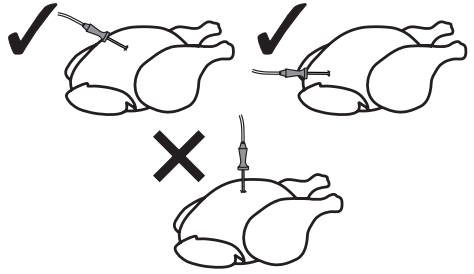

Hot temperature probe

Danger of burns

- Do not touch the stem or the tip of the probe after use.
- Wear oven gloves when using the probe.



Improper use

Risk of damage to surfaces

- Take care not to scratch or damage enamelled or chrome-plated surfaces with the tip of the probe.



Improper use

Risk of injury

- Do not leave the temperature probe unattended.
- Do not allow children to play with the probe.
- Take care not to injure yourself on the sharp parts of the probe.



High temperature inside the oven during use

Danger of burns

- Wear oven gloves when using the probe.



Improper use

Risk of damage to temperature probe

- Do not pull the cable to remove the probe from the socket or from the food.
- No part of the probe should be allowed to come into contact with the walls of the oven cavity, the heating elements, the racks or the trays when they are still hot.
- When not in use, the probe should not be kept inside the appliance.
- Make sure that the plug of the probe is fully inserted into the socket.
- Do not use the probe to place food into or to remove it from the oven.



Improper use

Risk of damage to the appliance

- Make sure that the plug of the probe is completely dry before inserting it into the socket.



Cleaning and maintenance

4 Cleaning and maintenance

4.1 Cleaning the appliance



We recommend the use of cleaning products distributed by the manufacturer.

Recommendations for cleaning the appliance

To keep the surfaces in good condition, they should be cleaned regularly after use. Let them cool first.

Ordinary daily cleaning

Always use only specific products that do not contain abrasives or chlorine-based acids.

Pour the product onto a damp cloth and wipe the surface, rinse thoroughly and dry with a soft cloth or a microfibre cloth.

Food stains or residues

Do not use steel sponges and sharp scrapers as they will damage the surface.

Use normal, non-abrasive products and a wooden or plastic tool, if necessary. Rinse thoroughly and dry with a soft cloth or a microfibre cloth.

4.2 Cleaning the door

The glass in the door should always be kept thoroughly clean. Use absorbent kitchen roll. In case of stubborn dirt, wash with a damp sponge and an ordinary detergent.



We recommend the use of cleaning products distributed by the manufacturer.

Removing the door

Cleaning the oven door is significantly facilitated as the internal glass pane can be opened.

- 1) Open the door.
- 2) Pull the upper and lower caps to remove them.

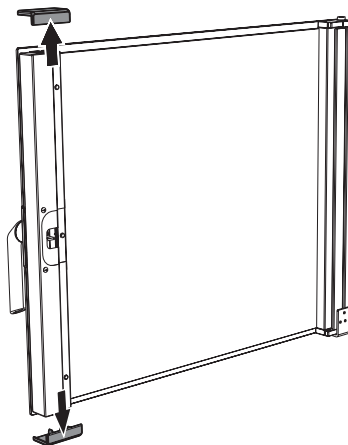



- 3) Open the internal glass pane.

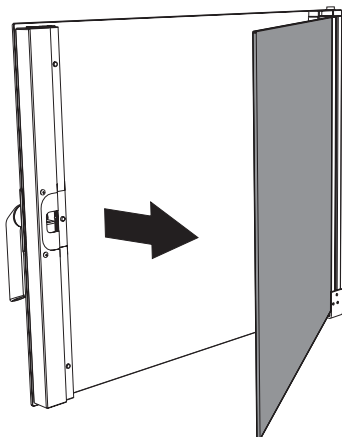

- 6) Reposition the upper and lower caps in their seats, applying light pressure.

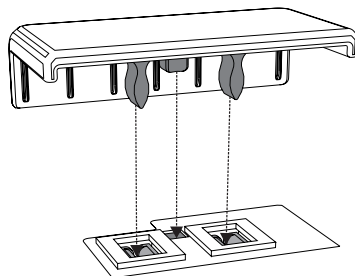

- 4) Clean both the interior and exterior of the glass panes. Use absorbent kitchen roll. In case of stubborn dirt, wash with a damp sponge and neutral detergent.
- 5) After cleaning, close the internal glass pane again.

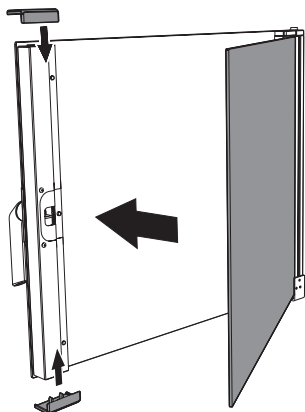



Cleaning and maintenance

4.3 Cleaning the oven cavity

In order to keep your oven in the best possible condition, clean it regularly after letting it cool down.

Avoid letting food residue dry inside the oven cavity, as this could damage the surfaces.

Take out all removable parts before cleaning.

For easier cleaning, we recommend removing:

- The door
- Tray support frames
- The seal.



In the event you are using specific cleaning products, we recommend running the oven at maximum temperature for 15-20 minutes in order to eliminate any residue.

Manual washing system (on some models only)



High temperature steam

Danger of burns

- DO NOT use the spray head if the oven is hot.
- If the oven is still hot, start the **Cooling** function (“Special functions”) and wait until it has finished.

The appliance is equipped with a manual washing system to make it easier to clean the oven cavity.

Water can be dispensed directly into the oven cavity using the retractable spray head.

- 1) Extract the spray head.

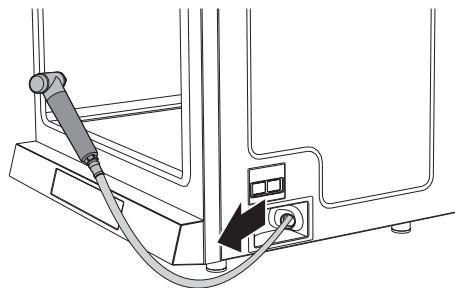

- 2) The amount it is extracted can be adjusted by stopping whenever you hear a metallic click (total 4).
- 3) Press the button on the back of the spray head to dispense water.
- 4) To rewind the hose, pull the spray head slightly and guide it carefully into its housing.
- 5) Sprinkle the walls of the oven cavity with a specific cleaning product.
- 6) Close the door and operate the appliance at maximum temperature for about 15 minutes.
- 7) Once it has cooled, repeat the manual cleaning cycle using the spray head.
- 8) Remove any residues manually and dry thoroughly.



During cleaning, water may reach the front panel and the edge of the oven cavity. This is not hazardous and will not cause malfunctions.



Cleaning the core probe



Improper cleaning

Risk of damage to the probe

- Do not wash the probe in a dishwasher.
- Dry the entire probe thoroughly after washing it.

After use, the temperature probe must be cleaned after it has cooled down. Only use water, neutral washing up detergent and a soft sponge to clean the metal part and the plastic handle of the temperature probe.

Do not under any circumstances wash it in a dishwasher, as it will damage the electronic components of the plug.

Dry thoroughly after cleaning.

Removing the tray support frames

Removing the tray support frames enables the sides to be cleaned more easily.

- 1) Unscrew the fastening ring nuts completely.

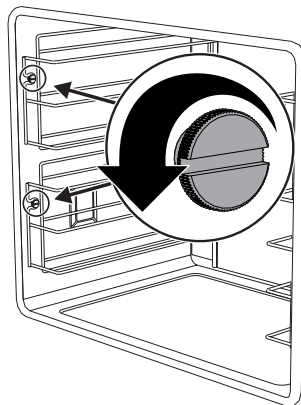

- 2) Remove the tray support frames from their seats on the deflector and remove them from the oven.
- 3) After cleaning, put the tray support frames back in the oven and fasten them with the fastening ring nuts.



Cleaning and maintenance

4.4 Extraordinary maintenance

Removing the door seal

To remove the seal:

- Pull the seal outwards to remove it.

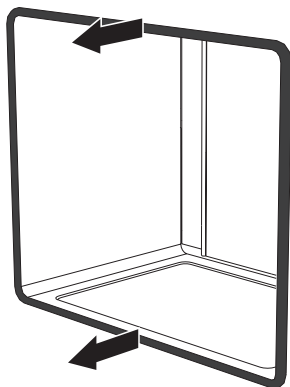

To refit the seal:

- Position the seal in the groove at the front, then press carefully down on it until it adheres to the face of the appliance.

Seal maintenance tips

The seal should be soft and elastic.

- To keep the seal clean, use a non-abrasive sponge and wash with lukewarm water.

Replacing the internal light bulb (some models only)



Live parts

Danger of electrocution

Disconnect the appliance power supply.



The oven is fitted with two 40W light bulbs.

- 1) Completely remove all accessories from inside the oven.
- 2) Remove the rack/tray support frames.
- 3) Remove the bulb cover using a tool (e.g. a screwdriver).



Take care not to scratch the surface of the oven cavity.

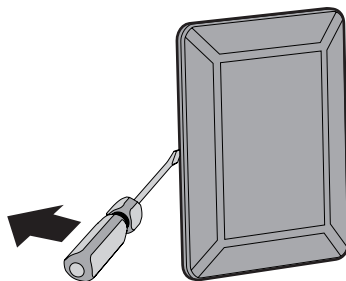



- 4) Slide out and remove the light bulb.

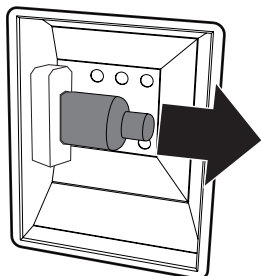

- Replacing the internal light bulb (some models only)



Risk of malfunction

Risk of damage to the appliance

- Place the glass and the seal correctly around the edge of the bulb compartment.
- Take care not to crack or chip the glass.

EN



Do not touch the halogen light bulb directly with your fingers, but wrap it in insulating material.

- 5) Fit the new light bulb.
6) Refit the cover. Ensure the moulded part of the glass (A) is facing the door.

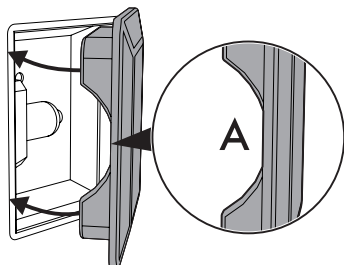

- 7) Press the cover completely down so that it attaches perfectly to the bulb support.

- 1) Completely remove all accessories from inside the oven.
2) Remove the rack/tray support frames.
3) Unscrew the screws at the 4 corners of the light bulb compartment cover.

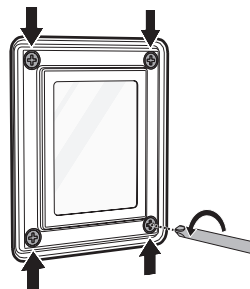

Take care not to let the internal seal and the glass fall into the lamp compartment.

- 4) Slide out and remove the light bulb.

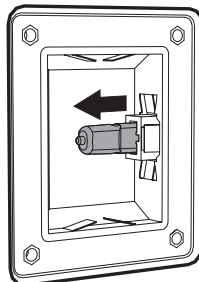



Cleaning and maintenance

- 5) Fit the new light bulb.
- 6) Place the glass (2) on the inside edge of the light bulb cover (3) and place the seal (1) on it. Then insert 2 of the screws that were previously removed (4) in 2 diagonally opposite holes.

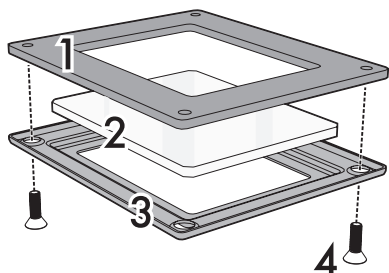

- 7) Place the cover on and tighten the screws.
- 8) Insert the 2 remaining screws and tighten them. This product meets current safety regulations for electrical appliances. To prevent safety hazards for users, all technical inspections or repairs must be carried out by qualified personnel.



If the appliance is not working properly, before calling Technical Support, ensure that the procedures listed above have been performed.

Regular Maintenance

- The appliance must be checked over thoroughly by a qualified technician on a regular basis (at least once a year).
- Any maintenance work must only be performed by a qualified technician.
- Before performing any kind of maintenance, unplug the appliance from the mains and wait for it to cool down if it has recently been used.



4.5 If the appliance is not working properly

Problem	Possible solution
The appliance is not working properly	<ul style="list-style-type: none">• The plug is not correctly inserted in the socket.• The electrical system is damaged or not working properly.• The fuses have blown or the circuit breakers are off/have tripped.
The appliance cooks food either too slowly or too quickly	<ul style="list-style-type: none">• The temperature setting is incorrect.
Moisture forms inside the oven and on foods	<ul style="list-style-type: none">• Food is being left in the oven for too long after cooking. Do not leave it in the oven for more than 15-20 minutes after the end of the cooking time.

Installation

5 Installation

5.1 Electrical connection



The terminal indicated by the  symbol links up parts that are normally earthed. Connect the appliances appropriately using this terminal in order to make sure that they are equipotential.



If the phase voltage drops below 190V~, the performance of the oven may suffer, not due to the product itself.

General information

Check the grid characteristics against the data indicated on the plate. The identification plate bearing the technical data, serial number and brand name is visibly positioned on the appliance. Do not remove this plate for any reason.

Ground the appliance using a wire that is 20 mm longer than the other wires. The appliance is provided with a five-core H07RN-F cable (5 x 1.5 mm² referring to the cross section of the internal conductor).

Connection modes

- 220-240 V 3~

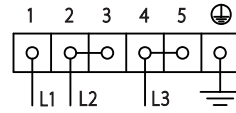

Four-core cable 4 x 6 mm².

- 380-415 V 3N~

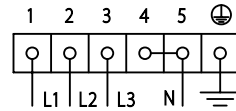

Five-core cable 5 x 2.5 mm².



The values indicated refer to the cross-section of the internal conductor.

Fixed connection

Fit the power line with an all-pole circuit breaker in compliance with installation regulations.

The circuit breaker should be located near the appliance and in an easily reachable position.

Connection with plug and socket

Check that the plug (not supplied) and power socket are compatible and of adequate capacity for the maximum current draw of the appliance.

Avoid using adapters and shunts as these could cause overheating and a risk of burns.

Installation

Cable replacement



Power voltage

Danger of electrocution

- Disconnect the mains power supply.
- Replacement of the electrical connection cable must only be carried out by qualified technical personnel.

- 1) The terminal board is located in the lower right corner on the back of the appliance.

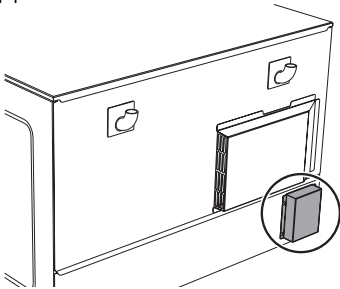

- 2) Unscrew the screws shown in the figure and remove the external cover from the terminal board.

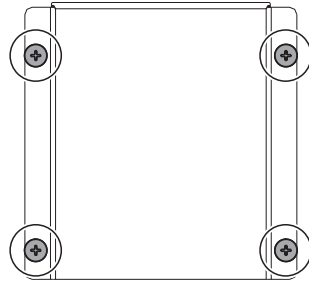

- 3) Use a flat-head screwdriver to release and lift the internal cover in order to access the terminal board.

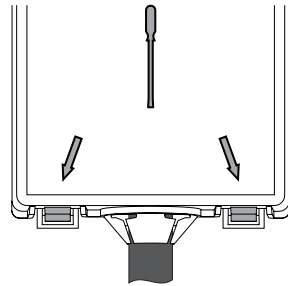

- 4) Replace the cable.
- 5) Make sure that the cables follow the best route in order to avoid any contact with the appliance.
- 6) Follow the instructions in reverse to replace the cover and the cable gland.

Installation

5.2 Water connection



Improper use

Risk of damage to the appliance

- If the water pipe is new or has not been used for a long time, before making the connection, let the water flow to ensure that it is clear and free from impurities.
- The inlet pressure should be between 50 kPa min. and 500 kPa max.

The openings for the water and drain connections are located on the rear panel of the appliance. Depending on the model, these are used for the internal humidification and manual washing systems.

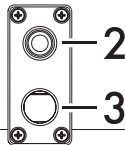

- 1 Internal humidification connection.
- 2 Washing water inlet (on some models only).
- 3 Drain outlet (on some models only).

Connect inlets 1 and 2 to a threaded $\frac{3}{4}$ " water outlet.

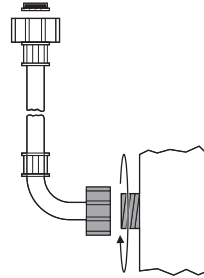

Washing water drain (on some models only)



High temperature water

Danger of burns

- The waste water may be very hot.
- The drainage pipes must be able to withstand high temperatures (at least 90°C).
- Do not use metal pipes.

The water is discharged by gravity through a pipe or hose connected to the appliance's drain outlet (3) and connected to a waste water drainage system.

The characteristics of the drainage system must be as follows:

- Maximum length: 1 metre. Minimum length: 30 cm.
- minimum inclination 4°.
- Minimum pipe diameter 30mm.
- It must be fitted with a U syphon (not provided, detail A in the following figures).

Installation



If you cook mainly fatty foods, to avoid build up and blockages in the piping, DO NOT install the syphon and discharge the waste water directly into a drainage gate (Figure 3).

- Free from kinks and obstructions.
- If multiple appliances are installed, make sure that the drainage pipes are of a suitable size to allow the water to drain properly.
- If it is not possible to connect the appliance permanently to a drainage system, it is recommended to seal the drain outlet with a removable cover.

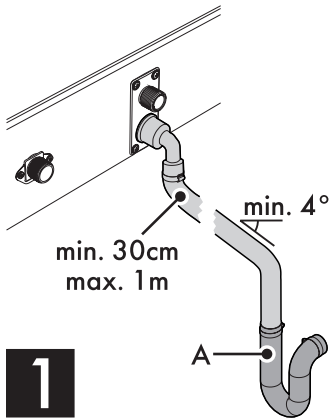

1 Direct discharge into a drainage system

- In the cases shown in figures 2 and 3, keep a minimum distance of 25 mm between the end of the pipe and the drainage zone.

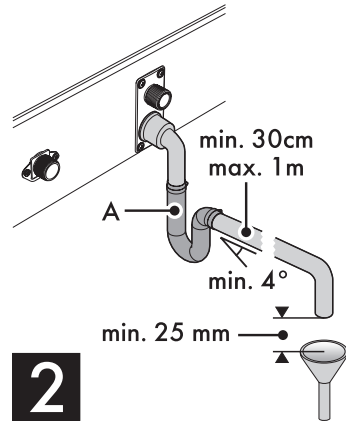

2 Drainage via a drainage manifold

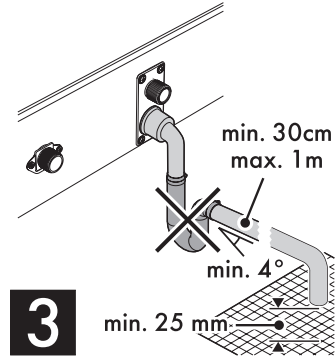

3 Drainage without syphon into a drainage grate



In the cases shown in figures 2 and 3, the drainage zone should be located away from the oven to prevent the infiltration of odours.

Installation

5.3 Positioning



Heavy appliance
Crushing hazard

- Position the appliance with the aid of a second person.



Pressure on the open door
Risk of damage to the appliance

- Never use the open door to lever the appliance into place when fitting.
- Avoid exerting too much pressure on the oven door when open.



Heat production during
appliance operation
Risk of fire

- Veneers, adhesives or plastic coatings on adjacent furniture should be temperature-resistant (no less than 90°C).



Improper installation
Risk of injury

- The appliance support base should not exceed a height of 1.60 m from the floor.

Levelling

Level the appliance on the ground using the adjustable feet. The foot has a range of 10 mm.

Steam outlet pipe

There are two exhaust flues on the back of the appliance (depending on the model) to discharge the steam produced during cooking.

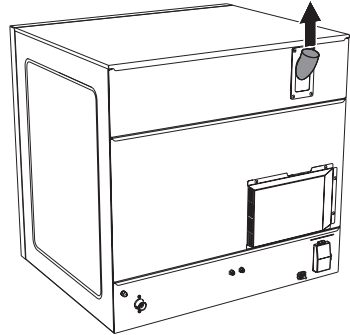

These must be left free of any obstruction. Avoid crushing and contact with any walls.

Installation

Multiple installations



Weight: 71 kg

Place the appliance at a distance of at least 50 mm from any back wall and at 30 mm from any side wall. Keep a minimum distance of 50 mm between appliances if multiple appliances are installed alongside each other.



Do not install the appliance on the floor.

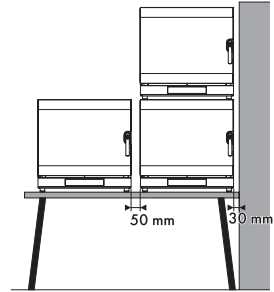

The appliance must be installed on a worktop.

Stacked installation



Improper installation

Risk of damage to the appliance

- It is not possible to stack the appliances one on top of another without having first installed the appropriate stacking kit (available on request). This kit must be fitted to both appliances.

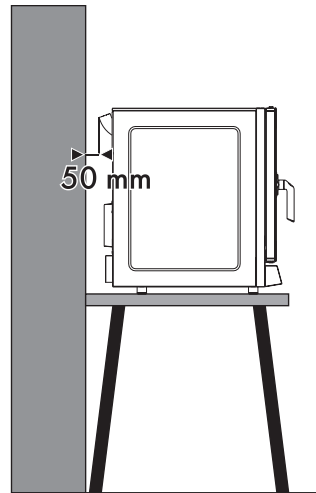

Installation



High food temperature
Danger of burns

- For safety reasons, **DO NOT** position the uppermost tray at a height above 160 cm.
- If necessary, it is **MANDATORY** to apply the supplied adhesive label at the height indicated in the figure below.

